

Derwent
Top 100
Global
Innovator
2020

MMP Series

Smart Electronic Motor Protection Relays





Innovative Upgrade of Motor Control Panel!

More compact and Safer! We implement perfect motor protection.



- Power, Voltage, Current (measurement error: 1%)
- Power, Voltage, Current, Power Factor Protection
- Harmonic measurement (1st to 16th)
- Diverse motor starting types (Full voltage, Y-D, Reversible, Reactor, Inverter Starting)
- Modbus communication and 4~20mA

One model with various motor starting types
One S-EMPR model is applicable to various motor starting types, such as full voltage starting, Y- Δ starting, reversible starting, Reactor starting, and Inverter starting.

A variety of SCADA functions based on sequence structure
With a simple sequence, it is possible to not only control local operation panel (LOP) and MCC panel, but conduct Supervisory Control And Data Acquisition through S PLC or DCS based auto operation and communication.



MMP Series

Smart Electronic Motor Protection Relays

- Current, Voltage, Power Measurement and Power Factor Protection
- Instantaneous interruption compensation and restarting
- Harmonic measurement (1st to 16th)
- Modbus communication and 4~20mA



Contents

- 04 Product characteristics
- 13 Rated specifications / Model numbering system
- 14 Operation & setting method
- 26 Terminal configuration / Wiring & cable connection
- 32 Dimensions

Product characteristics

Convenience



Comprehensive Digital Motor Protection Relay with the MCU (Microprocessor Control Unit)
Providing real-time processing and high precision



Applicable to inverter circuits

It can be installed in the downstream of a speed driver where harmonic noise exists. The allowable frequency range is 10 to 400Hz.

A harmonic filter must be used if THD (Total Harmonic Distortion) is over 30%.

* Set the ground fault mode off to avoid the trip due to current unbalance.

* Voltage parameters are not available. Power measurement accuracy is not guaranteed.



Function to store the cause(s) of failure / Fault

Up to 5 motor failure events may be saved in the system, so that the failure history can be easily identified.



Communication function (RS485 Modbus and 4~20mA output)

With universal RS485/Modbus communication types, it is possible to establish various system and communication networks.

Analog current signal (4~20mA) output is compatible with conventional TD(Transducer) based system.



A wide range of reset functions

Manual/Automatic/Electrical reset functions are provided for user convenience.



Date information display

When a failure occurs, the date and time of failure occurrence are saved in the system to accurately identify the date of motor failure.



Password setting

When changing the set values, a password must be inserted.



Total operating time and operating time setting

When the predefined operating time has elapsed, related information is displayed so that operators may replace the motor bearing and check the refueling cycle.



Quick Setup

Same setting for another devices in different panels can be done simply via the display unit.

Reliability



Thermal heat build-up inverse time/inverse time/definite time selection function

It is possible to select one of two types of inverse time and definite time in order to protect a motor perfectly.



Wide setting range and Dual protection

Providing Ground fault protection by dual detections -Zero-phase current and Residual current levels.



Up to 100A the device can be used without external CT to providing convenience and cost-effective solution.



Various Motor Starting Modes

In a Single Device several starting modes of operation available : Full voltage start, Y- Δ start, Reversible start, Reactor start, Inverter start.



Metering of Current, Voltage and Energy (with 1% accuracy for A & V)

Real-time energy metering with high accuracy to support energy-saving Current /Voltage THD measurements (16 harmonic)



Carrying out complex relay functions related to Current, Voltage, Energy and Power Factor

Overpower alarm supported for energy monitoring



Self-diagnosis and Sequence monitoring

Providing a self-diagnosis function such as internal memory check in order to check fault conditions quickly



Power loss and Restarting

Device restarts after the momentary power loss for less than 30 seconds and returns to the former state. Time-delay setting between 0 to 300 sec. is available to prevent overload from all the motors' restarting at the same time.



Frequent-Starting Protection

The number of automatic resets for the set time (20 minutes) is settable to provide frequent-starting protection.

Product characteristics

Protective functions

Product functions

Type	Function	MMP-C (Current type)	MMP-S (Select ground fault)	MMP-P (Power type)	MMP-IR (Insulation Resistance)
Currents	Overcurrent	●	●	●	●
	Locked Rotor	●	●	●	●
	Stall	●	●	●	●
	Phase loss	●	●	●	●
	Imbalance	●	●	●	●
	Phase reversal overcurrent	●	●	●	●
	Undercurrent	●	●	●	●
	Zero-phase ground current	●	●	●	●
	Residual ground current	●	●	●	●
	Instanteous	●	●	●	●
Select ground fault	-	●	-	-	
Voltages	Overvoltage	-	-	●	-
	Undervoltage	-	-	●	-
	Phase loss	-	-	●	-
	Imbalance	-	-	●	-
	Phase reversal overvoltage	-	-	●	-
	ground current overvoltage	-	●	-	-
Power	Overpower	-	-	●(Alarm)	-
	Underpower	-	-	●(Alarm)	-
	Over power factor	-	-	●	-
	Under power factor	-	-	●	-
Additional function	Insulation resistance	-	-	-	●
	Motor temperature	-	-	-	●

Measurement function

Measurement	Range	Accuracy(%)	Remarks
Voltage(V)	0.00V~9999V	±1.0%	Phase1 : Phase voltage, Phase3 : Line voltage
Current(A)	0.00A~9999A	±1.0%	Phase current
Zero-phase current(In)	0.00A~9999A	±3.0%	-
Reverse current(I ₂)	0.00A~9999A	±3.0%	-
Active power(W)	0.000W~999.9MW	±1.0%	Forward
Reactive power(VAR)	0.000W~999.9MVAR	±1.0%	Forward
Active power amount(WH)	0.000W~999.9MWH	±1.0%	-
Reactive power amount(WVARH)	0.000W~999.9MVARH	±1.0%	-
PF	-1.00~1.00	±0.03	cosθ
Voltage hamonics(%)	0~100%	±5.0%	2 nd -16 th odd harmonics
Current hamonics(%)	0~100%	±5.0%	2 nd -16 th odd harmonics
Insulation Resistance	0.2MΩ~50MΩ	±10%	-
Motor temperature	-50°C~200°C	±10%	-

Current protection

Over current

The device provides overcurrent protection either with inverse-time or with definite-time element.

1) Inverse-time delay curve

The trip time decreases as the overcurrent increases in an inverse-time curve.

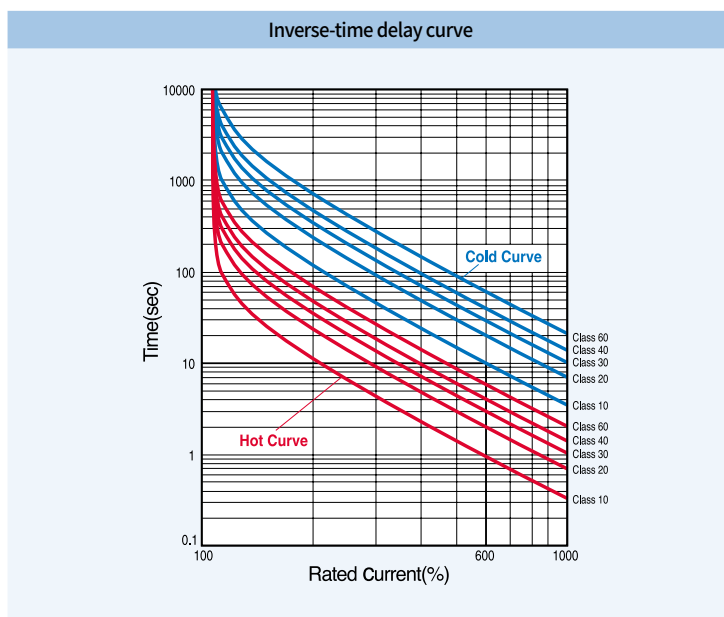

2) Definite-time delay curve

The operating time is unaffected by the magnitude of the overcurrent.

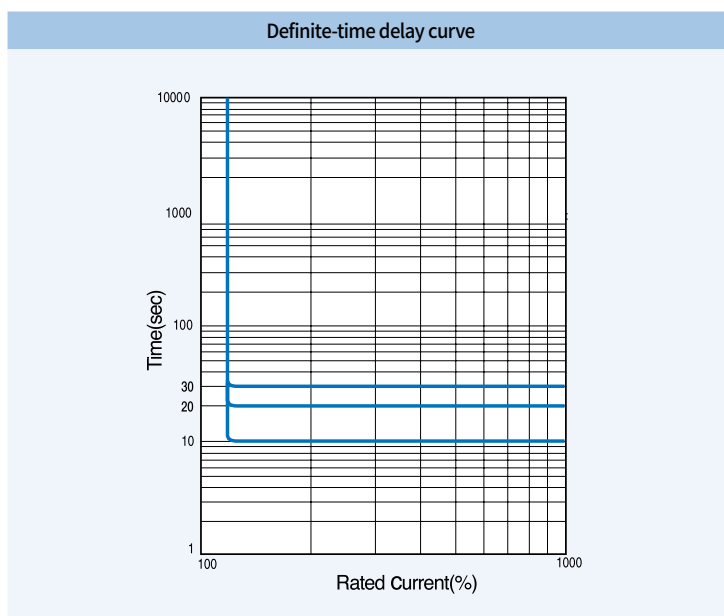

Stall/Locked rotor

Stall activates when the motor is unable to rotate due to any externally mechanical obstruction, and Lock activates due to internal issue of the motor.

Phase fail/Phase unbalance

The motor is unable to start under phase loss. If it occurs while the motor is running it causes motor stopping by lack of torque, or significant rotor heating by reverse current. The S-EMPR calculates the percent three-phase unbalance current. If it exceeds 70%, which is determined to be phase loss, the device trips within 1.5 sec. If it is between 10 to 70% the device trips within 3 sec. This function is disabled for a single-phase mode.

Product characteristics

Reverse phase

This protection is for preventing the motor from reverse rotation. The device detects motor phase rotation and trips within 0.1 sec. if phase sequence is incorrect. It detects when the motor is starting.

* This function is disabled for a single-phase mode.

Under current

If the real load current falls below the warning or trip level for longer than the time-delay setting, the device can issue a warning or trip signal.

Ground fault protection

Ground fault

Stall activates when the motor is unable to rotate due to any externally mechanical obstruction, and Lock activates due to internal issue of the motor.

Zero-phase ground current

ZCT in or out of the product is used to detect zero current flowing in three phases.

Selective ground fault

If a non-grounding system has ground fault, the current over the zero current transformer of each distribution line flows from the load side to the power side in a good line, and from the power side to the load side in a bad line. This protection function is able to select and block a bad line by determining the direction of failure current on the basis of the zero voltage.

Instance

While an AC motor is running, if an actual load current value is higher than an set value of instantaneous current, Trip occurs in 50msec.

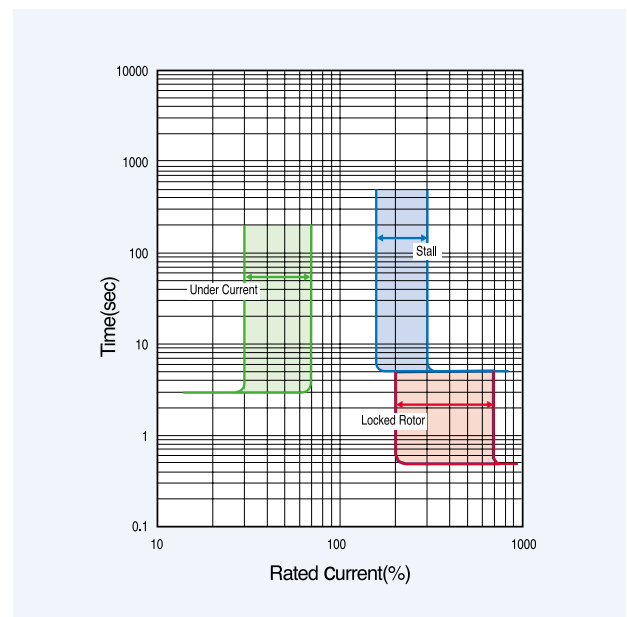

Selective ground fault protection

If a non-grounding system has ground fault, the current over the zero current transformer of each distribution line flows from the load side to the power side in a good line, and from the power side to the load side in a bad line. This protection function is able to select and block a bad line by determining the direction of failure current on the basis of the zero voltage.

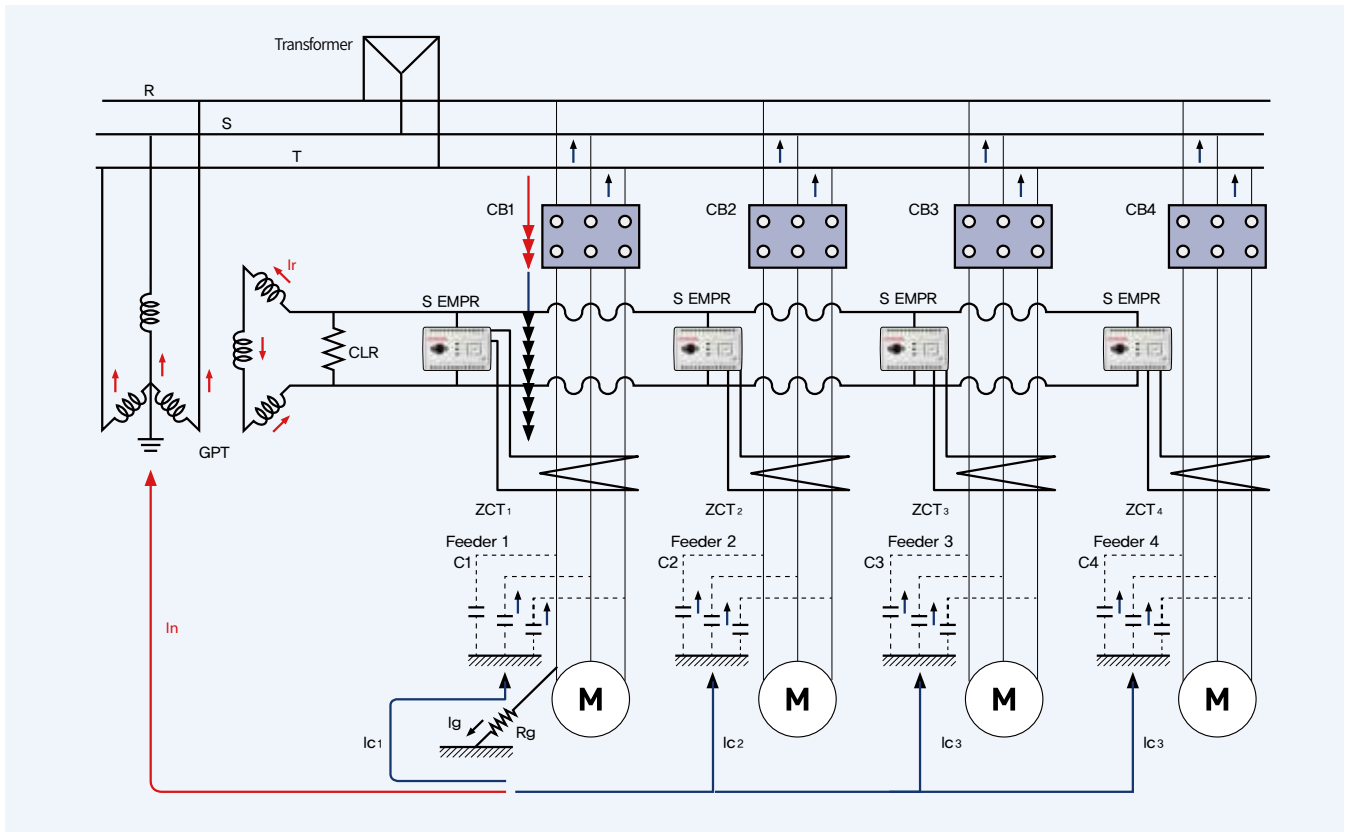

- ① - GPT : Grounding Potential Transformer
- ② - ZCT1, ZCT2, ZCT3, ZCT4: Zero current transformer
- ③ - CLR: Current-limiting resistor
- ④ - CB : Circuit breaker
- ⑤ - I_n : Current over GPT
- ⑥ - S-EMPR MMP S: Smart digital motor protection relay
- ⑦ - I_r : Current-limiting resistor current
- ⑧ - R_g : Ground fault resistance at ground fault point
- ⑨ - I_n : Current over GPT
- ⑩ - C1, C2, C3, C4 : Line capacitance of each feeder
- ⑪ - I_g : Ground fault current
- ⑫ - I_c : Line charging current ($I_{c1}+I_{c2}+I_{c3}+I_{c4}$)

Operating characteristic

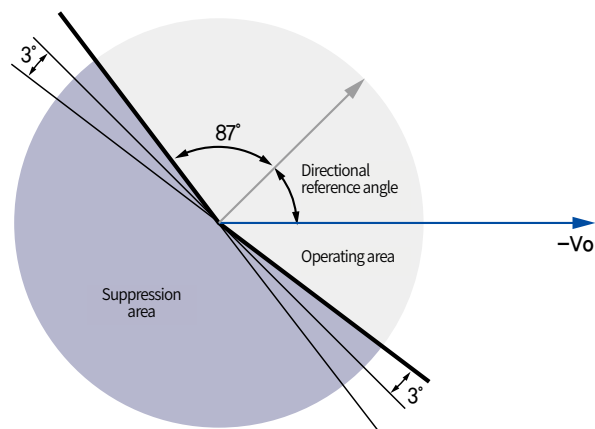

As shown the figure, the bad line (Feeder1) and the good line has an opposite current direction. With the use of this current direction, it is possible to select one. If another line has a failure, the charging current of the line flows in an opposite direction from the current flowing at the time of the accident. Therefore, it does not run.

In a non-grounding system, the ground fault current is the sum of the line charging current and the limiting-resistance current. Since it is relatively small, zero CT(ZCT) is needed. This product has ZCT built in so that it is possible to make a system simply.

Product characteristics

Voltage & Power protection

Over current

Overvoltage protection detects the voltage levels and operates if they are greater than the setting to protect the sensitive loads or circuits against such condition.

Under voltage

If the voltage levels fall below the setting the Undervoltage protection issues a warning or trip signal to protect the sensitive loads such as a inductive motor.

Phase fail/Phase unbalance

This protection operates if the percent phase-to-phase voltage unbalance is greater than the setting.

Used to prevent an excessive vibration of three-phase induction motor and a damage of the stator and rotor windings.

This function is disabled under a single-phase mode.

Reverse phase

This protection operates if the percent phase reversal voltage is greater than the setting.

It detects when the motor is starting. This function is disabled for a single-phase mode.

Over power

The overpower element operates if the three-phase active power exceeds the setting level.

This element can be used to prevent the power from entering the generator before disconnecting from the system when the generator operation is finished.

Under power

The underpower element operates if the three-phase active power falls below the setting level.

Over power factor

The over power factor element operates if the power factor exceeds the setting level.

If the load is very small, especially for no-load the capacitive current may flow due to overcapacity of the capacitor in line, which causes the power loss of the line and transformer, and electric stress on motors. This element can be used to protect against such current.

Under power factor

The under power factor element operates if the power factor falls below the setting level.

If the power factor of a customer falls below that of a generator in a power plant the generator current increases over the rated current or the power output is limited. For this reason, the power factor of a customer is regulated.

In addition, the under power factor causes the increase of the input current which prevents the temperature rise in cables, transformers and motors.

Communications

Modbus specification

Communication number	1~247
Baud rate	9600, 19200, 38400 bps
Communication Parity	None, Even, Odd
Stop Bit	1bit (fixed)
Communication data swap	OFF / ON (Limited to float, long data of 0x04 (Read Input Registers)
Operation mode	Differential
Communication distance	Max. 1.2km
Cable	RS-485 Shielded Twist 2-Pair Cable
Transmission Method	Half-Duplex-
Max. In/Output Voltage	-7V~+12V

Communication system configuration

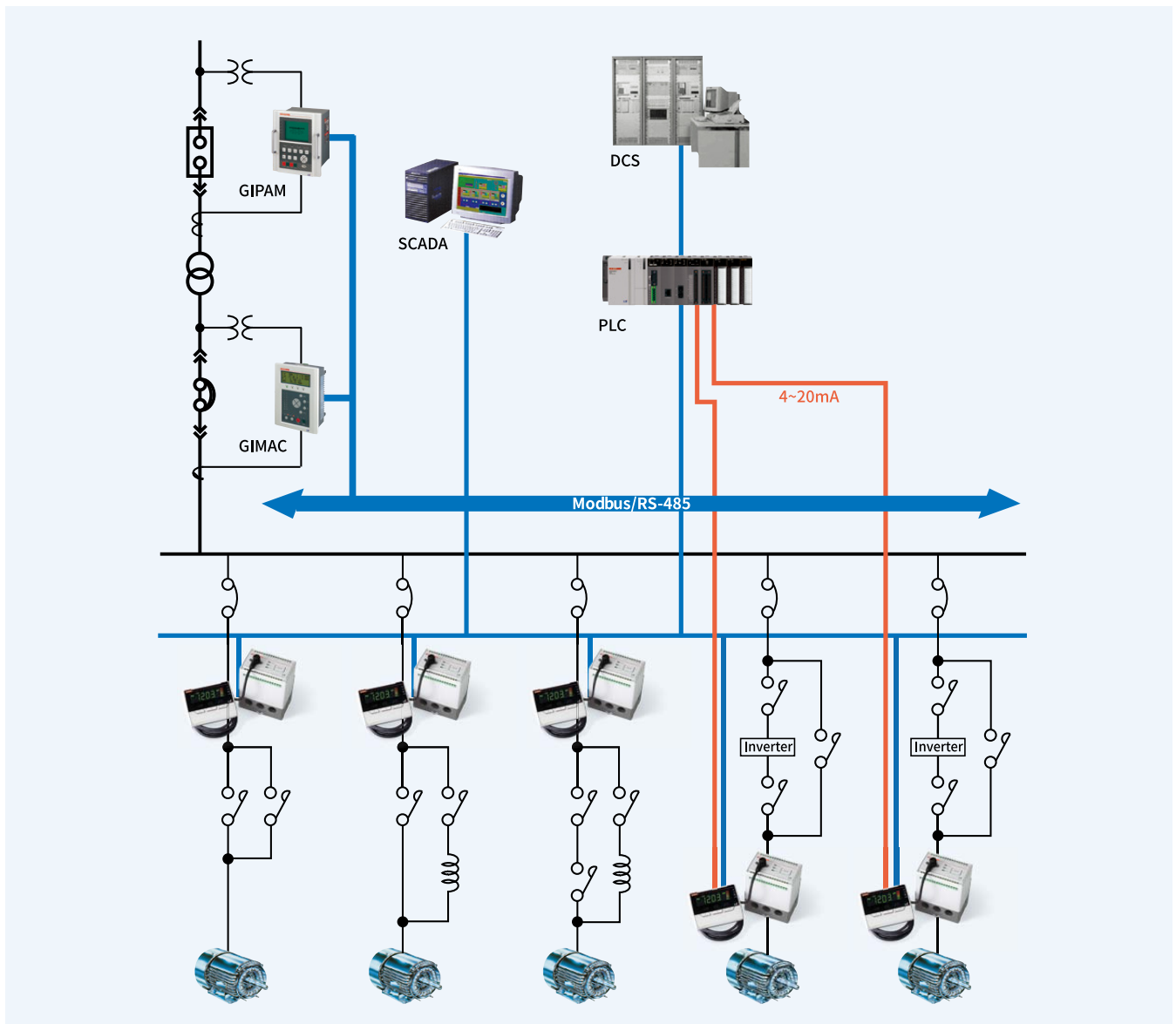

Product characteristics

Analog (4~20mA) output function

Specification

- This function measures the maximum out of the 3-phase currents and converts it into DC 4~20mA for output, which can be converted back to the original value by a digital meter.

- 20mA Output Settings : 0.5~10A or 5~100A

Note) 1. In the 0.5~10A setting mode the device starts to measure from 0.15A, which means the current 0.15A or less is measured as 0A and the output becomes 4mA.
(0.15A when one > 4mA is being a real measurement)
2. Accuracy at 25°C : ± 0.15% / °C

- During stopping : 4mA
- Rated setting value or more : 20mA
- Load : 500Ω or less

Note) The allowable burden of cable must be less than 500Ω. Shielded cables are recommended in consideration of the resistance of the receiving meter (typically 250Ω) and the line resistance.

$$\begin{aligned}
 \text{* Output current} &= \frac{(I_{\text{upper}} - I_{\text{lower}})}{\text{TD setting}} \times \text{load current} + 4\text{mA} \\
 &= \frac{16\text{mA}}{\text{TD setting}} \times \text{load current} + 4\text{mA}
 \end{aligned}$$

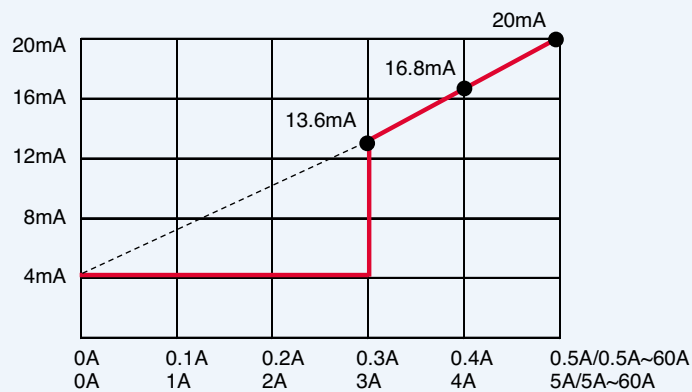

Analog output for 10A (100A) output setting

Rated specifications

Connection		Tunnel type (Passing through CT holes)
Operation characteristic		Thermal-inverse / Inverse / Definite
Rated current		0.5~10A/5~100A (Select Rated on Order)
Display screen		4 digit, 7-Segment, LED
Control Power		110Vac or 220Vac 50/60Hz
Reset	Auto	1-20 minutes
	Manual	ON / OFF selectable
Mounting		Display unit : separately mountable
Accuracy		Current and voltage metering : $\pm 1\%$ of rating or $\pm 2\%$ of minimum rating 4~20mA output : $\pm 5\%$
Time delay	Start	1-200 seconds
	Operation	1-60 seconds
Auxiliary contacts	6 contacts (3A / 250VAC at resistive load, power type based)	
	Contact minimum load	10mA / 5VDC
ZCT input		Basic installation of built-in ZCT External ZCT (200mA/1.5mA, universal ZCT connectable)
I/O assured voltage	110V Type	63V $\pm 10\%$
	220V Type	140V $\pm 10\%$
Environment	Operation Temp.	-10~55°C
	Storage Temp.	-20~70°C
	Humidity	within 80% RH, no condensation
Insulation resistance		100M Ω /500VDC
Lightning impulse voltage		1.2 \times 50 μ s 5kV standard waveform applied
Fast Transient		2kV/1Min
Power consumption		5W or under

Model numbering system

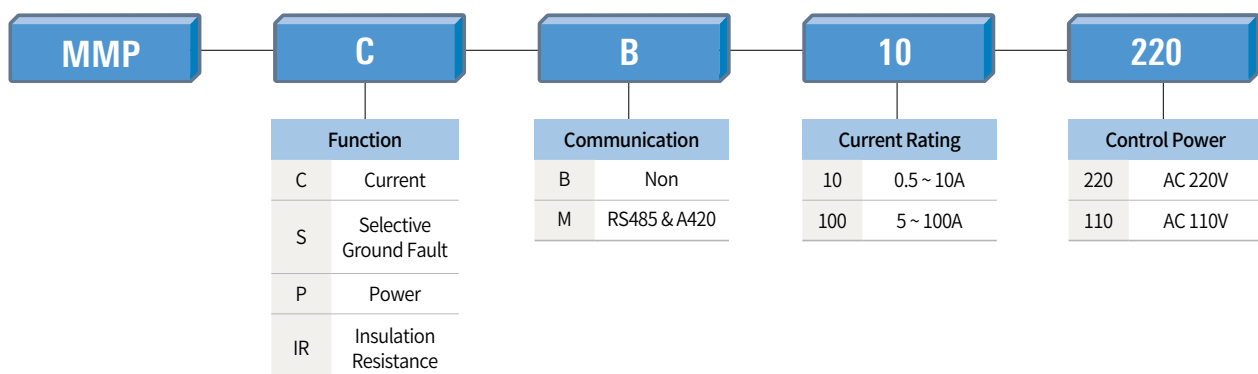

Operation and Setting

MMP-CB/CM/PB/PM/SB/SM-10/100 Model

Before starting the motor, proceed as follows :

1. Connect the display unit to the main unit of the device and then turn on.

Verify that Power LED is switched on and the measurement screen is displayed.

- 1) Verify the operations of ON, REV and STOP keys which are used to control motor starting. Press ON key and then the red LED above the key is switched on and motor on signal is issued . Press STOP key and then the green LED above the key is switched on and motor on signal is stopped .

Note) REV key is activated when the motor control is set to reverse starting mode.

- 2) Verify the operations of a mode control key. Each time pressing L / R key the control mode changes : MCC → AUTO → REMOTE → COM
- 3) When the device is booted up the measurement screen is display by default. Pressing Enter key allows to access the modes : Group → Menu → Setting value. Press Esc key to return to the previous mode. Use Up & Down keys to change values in the screens of Measurement, Group, Menu, Setting. When the relay / alarm operates press Reset key to reset.

Note) refer to a manual for the details.

2. Verify the operations of Test function and Reset key through trip.

- 1) Verify the wiring first. Press Enter key to access Group menu, and use Up / Down keys to access B Group as shown "b-gr" and press Enter to access Menu with displaying "1.Loc". Use Up / Down keys to access "6.r-p" which denotes Phase reveral menu, and press Enter to access "CHEC" which denotes Setting value, and press Enter to view current wiring information.

Note) 1. The phase information is displayed only when current is applied. If there is no current "-" is displayed.

2. Voltage wiring information is available via "c-gr" (C group) → "8.urp" (Voltage phase reveral settings) → "CHEC" → Pressing Enter Key. The phase information is available when a voltage is applied.

- 2) Turn on the motor and access "d-gr" which denotes D group and move to "ESEL" menu using Up / Down keys and press Enter to access Fault items. Select the desired Fault item and press Enter to trip the device.
- 3) Press Reset key to reset the device and return to the measurement screen.

Note) In the first access to change a parameter "P-99" for password input is displayed. Press Up key to change it to "P-00" and press Enter and then Setting change is allowed. If there is no input for 2 minutes it returns to the measurement screen.

3. Check the settings.

- 1) At normal state pressing Enter key access mode "A-gr" which enables setting. Select the desired group using the Up / Down keys and press Enter key to enter the desired group. To enter previous mode, press the Esc key.
- 2) The desired group displays from No. 1 menu. Select the desired menu using the Up / Down keys and press Enter key to enter the setting mode. To enter previous mode, press the Esc key.
- 3) Press Up / Down keys in the setting screen and then "P-99" is displayed. Press Up / Down keys to change the password to "P-00" and press Enter to release it. After that select the desired value and press Enter to save the setting.

Note) Enter the date exactly when the power is turned on for the first time or recovered after the outage.

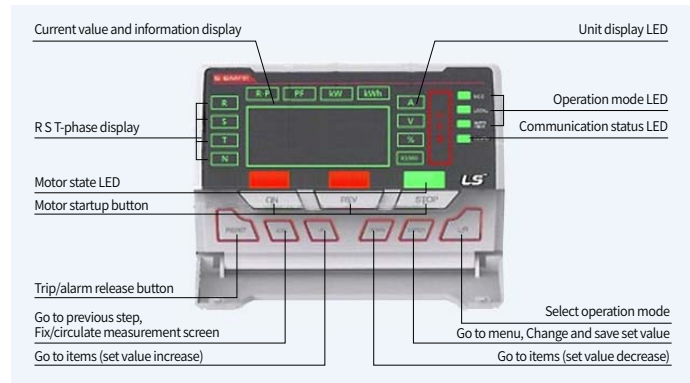

Menu List (MMP-CB/CM/PB/PM-10/100)

A-group

Group	Menu	Description	Setting range	Default
A	1P/HA	Single-phase / 3-phase	1P/3P	3P
	25-F	Frequency	50/60	60
	3CHA	Characteristics (Over Current Protection)	Off/dEF/th/n-th ^{Note 1)}	n-th
	40-t	Operating time	1~60sec (5/10/20/30/60)	60
	5d-t	Time Delay	1~200sec	200
	6r-C	Rated current (10, 100)	0.5~10/5~100	10
	7C/r	CT ratio ^{Note 2)}	0.25/0.5/1~200	1
	8d-r/U	Starting mode	dir/y-d/F-r/lnd/lut	dir
	9d-t	Y start time (lut start time)	1~120sec (lut : 0.1~1sec)	5 (0)
	10Yd	Y-D switching time	0.05/0.1/0.2	0.2
	11St	Outage compensation time	Off/1~30sec	Off
	12Sd	Restart time	0~300sec	0

Note) 1. Operating characteristic th denotes inverse-time curve with thermal-memory and n-th denotes inverse-time curve without thermal-memory .

2. For the 100A type there is no CT ratio as it is fixed as 1.

3. Some menu are not disabled depending on the related setting.

4. Phase reversal mode needs to be switched on only during test starting, or verify wiring via wiring CHEC function. it is recommended to turn off during normal running. .
(An error on phase reversal may occur due to noise.)

B-group

Group	Menu	Description	Setting range	Default	
B	1LoC	LOCK	Off/200~800%	Off	
	2StL	STALL	Off/150%~500%	Off	
	3P-F	Phase loss (current)	On/Off	On	
	4P-U	Phase unbalance (current)	Off/30~70%	Off	
	5Pd-t	Phase loss / unbalance Time-delay	0~200sec	0	
	6r-P	Phase reversal (current)	Off/On/CHEC ^{Note 1)}	Off	
	7C/r-t	Phase reversal operation time	0.1~1.0sec	0.1	
	8U-C	Undercurrent	Off/30~90%	Off	
	9Ec-t	ZCT selection (PC mV, 1.5mA)	100/1.5 ^{Note 2)}	Enbd	
	10GF	Ground fault (Zero-phase)	Off/0.03/0.05/0.1~3.0	Off	
	11Gn	Ground fault (Residual current)	Off/30~100%	Off	
	12G-t	Ground fault operation time	0.05~3.0sec	3.0	
	13Gd	Phase unbalance delay time	0~00sec	60	
	14I-C	Intance	OFF/10A type : ~100A ^{Note 3)} /100A type : ~800A, 100A or more: using external CT		OFF
	15AL	Output contact method	ALL I-tp, ALo, U-C, OrH ^{Note 4)}		
	16Ar	Current Y / N, Alarm	ON/60~110%		
	17th	THD (voltage)	0~100%		

Note) 1. When CHEC set value of negative sequence item is selected, additional wire information is displayed.

2. ZCT selection is set depending on whether company dedicated product or universal product in the market is used.

3. Tolerance guarantee scope for 10A type: ~100A/100A type: 600A for 50Hz, 720A for 60Hz

4. I-tp: Instantaneous trip, Circuit breaker trip (interlocked), ALo: Current alarm setting, U-C: When operating under low current factor, OrH: When the motor consecutive operating time is over the set value and when ALL is set, output (AUX-C3) will be released at the time of all current relay factor (including I-tp) operation.

Operation and Setting

C-group : Menu for power type activation

Group	Menu	Description	Setting range	Default
C	1r-u	Rated voltage (line to line)	110~480	380
	20-u	Over voltage	Off/105~130%	Off
	30-t	Over voltage operation time	1~30sec	30
	4U-u	Under voltage	Off/50~95%	Off
	5U-t	Under voltage operation time	1~30sec	30
	6uPF	Phasee loss (voltage)	Off/On	Off
	7uPU	Unbalance (voltage)	Off/5~40%	Off
	8urP	Phase reversal (voltage)	Off/On/CHEC	Off
	9urt	Phase reversal operation time	0.1~1.0sec	1
	10nP	Rated power	0.1~999.9KW	999.9
	110P	Over power	Off/100~800%	Off
	12Pt	Over power operation time	1~100sec	100
	13UP	Under power	Off/20~100%	Off
	14Pt	Under power operation time	1~100sec	100
	150F	Over power factor	Off/0.20~1.00	Off
	16Ft	Over power factor operation time	1~30sec	30
	17UF	Under power factor	Off/0.20~1.00	Off
	18Ft	Under power factor operation time	1~30sec	30
	19rY	Relay output selection	u-AL/u-tP	u-tP
	20.1P	Reactive power (meter)	0~999.9 Mvar	Unit : Kvar
21.1h	Free Power Amount	0~999.9 Mvah	Unit : Kvah	
22.th	THD (Free Power Amount)	0~100%	Unit : %	

D-group

Group	Menu	Description	Setting range	Default
D	1trt	Total running time	0~9999day / 0~23h / 0~59m	-
	2r-t	Running time	0~9999h / 0~59m	-
	35rt	Running time setting	Off/10~8760	Off
	4cch	Contacteur check	Off/On	Off
	55-d	Date ^{note 1)}	2013~2100y / 1~12 (Mon), 1~31 (Day) / 0~23h, 0~59m	2014 01.01. 0:00
	6ccc	Contacteur counter ^{note 2)}	-	-
	7FLt	Fault cause check ^{note 3)}	1. The most recent 2. The 2nd. recent 3. The 3rd. recent 4. The 4th. recent 5. The 5th. recent	-
	8A-r	Automatic reset time ^{note 4)}	OFF / 1~20m	Off
	9r-n	Automatic reset number Set number of times	Off/1-5	Off
	10Ad	Communication address ^{note 5)}	1~247	247
	11bs	Communication speed ^{note 5)}	9.6/19.2/38.4K	9.6K
	12SP	Swap ^{note 5)}	On/Off	Off
	13Pr	Parity setting ^{note 5)}	nonE/odd/EUEn	nonE
	14td	20mA setting ^{note 5)}	0.5~10/5~100	10/100
	r5t	Stored data deletion	All : for all subparameters A-P : active energy rA-P : reactive energy trt : total running time CCC : contacteur counter CALo : calories FALt : fault events	-
	tEst	Operation test	o-L : overcurrent test o-U : overvoltage test g-F : ground fault test I-C : instantaneous test	-

Note) 1. When power is supplied for the first time or recovered after blackout, date information (5.S-d) should be set up to enter the year, month, date, hour and minute.

2. The date setting can be stored after filling up month, day, hour and minute.

3. The trip cause can be stored up to 5 recent events and then the oldest event is deleted first.

4. Automatic recovery activates only in case of trip due to overload.

5. 10.Ad, 11.bs, 12.SP, 13.Pr, 14.td are available for communication type products.

6. Data clear and test can be inputted in the normal state, and test items can be viewed while a motor is switched on.

Operation and Setting

Menu List (MMP-SB/SM-10/100)

A-group

Group	Menu	Description	Setting range	Default
A	1P/3P	Single-phase / 3-phase	1P/3P	3P
	25-F	Frequency	50/60	60
	3CHA	Characteristics (Over Current Protection)	Off/dEF/th/n-th Note 1)	n-th
	40-t	Operating time	1~60sec (5/10/20/30/60)	60
	5d-t	Time Delay	1~200sec	200
	6r-C	Rated current (10, 100)	0.5~10/5~100	10
	7C/r	CT ratio Note 2)	0.25/0.5/1~200	1
	8drU	Starting mode	dir/y-d/F-r/lnd/lut	dir
	9d-t	Y start time (lut start time)	1~120sec (lut : 0.1~1sec)	5 (0)
	10Yd	Y-D switching time	0.05/0.1/0.2	0.2
	11St	Outage compensation time	Off/1~30sec	Off
	12Sd	Restart time	0~300sec	0

Note 1) Operating characteristic th denotes inverse-time curve with thermal-memory and n-th denotes inverse-time curve without thermal-memory.

2. For the 100A type there is no CT ratio as it is fixed as 1.

3. Some menu are not disabled depending on the related setting.

4. Phase reversal mode needs to be switched on only during test starting, or verify wiring via wiring CHEC function. it is recommended to turn off during normal running,.

(An error on phase reversal may occur due to noise.)

B-group

Group	Menu	Description	Setting range	Default	Remarks
B	1LoC	LOCK	Off/200~800%	Off	
	2StL	STALL	Off/150%~500%	Off	
	3P-F	Phase loss (current)	On/Off	On	✓
	4P-U	Phase unbalance (current)	Off/30~70%	Off	✓
	5Pd-t	Phase loss / unbalance Time-delay	0~200sec	0	✓
	6r-P	Phase reversal (current)	Off/On/CHEC Note 1)	Off	✓
	7C/r-t	Phase reversal operation time	0.1~1.0sec	0.1	✓
	8U-C	Undercurrent	Off/30~90%	Off	
	9Ec-t	ZCT selection (PC mV, 1.5mA)	100/1.5 Note 2)	Enbd	
	10GF	Ground fault (Zero-phase)	Off/0.03/0.05/0.1~3.0	Off	
	11Rn	Ground fault (Residual current)	Off/30~100%	Off	✓
	12St-t	Ground fault operation time	0.05~3.0sec	3.0	
	13Gr	Selective ground fault(SGR) current setting	Off/0.03/0.05/0.1~3.0	Off	
	14VU	Selective ground fault(SGR) voltage setting	8~80V	80	
	15RA	Selective ground fault(SGR) reference angle setting	0~90 angular measure	0	
	16St-t	Selective ground fault(SGR) operating time	0.05~3.0sec.	3.0	
	17Gd	Ground fault Time-delay(Ground fault, SGR)	0~200sec	60	
	18IC	Instantaneous protection	Off/500~5000% Note 3)	Off	
	19AL	Output contact method	I-tp, ALo, U-C, OrH Note 4)	I-tp	
	20Ar	Current Y / N, Alarm	On/60~110%	On	
21oV	Ground fault Overvoltage	Off/8~80V	Off		
22ot	Operating time	0.05~3.0sec	3.0		
23rY	Relay output selection	u-AL, ATP	u-AL		
24th	THD (voltage)	0~100%	Unit : %		

Note 1) If CHEC set value of reverse phase is selected, wiring information additionally appears.

2. ZCT is selected differently depending on whether to use our product or other universal products.

3. Tolerance guarantee scope for 10A type: ~100A/100A type: 600A for 50Hz, 720A for 60Hz

4. I-tp: Instantaneous trip, circuit breaker trip(interaction), ALo: instantaneous alarm, U-C: in case of low-current operation, OrH: if a motor's continuous operating time is higher than a set value In case of ATP setting, when all current relay factors (including I-tp) work, output (AUX-C3) appears.

5. No support is given for a single-phase motor.

D-group

Group	Menu	Description	Setting range	Default
D	1trt	Total running time	0~9999day / 0~23h / 0~59m	-
	2r-t	Running time	0~9999h / 0~59m	-
	3Srt	Running time setting	Off/10~8760	Off
	4CCh	Contacteur check	Off/On	Off
	5S-d	Date ^{note 1)}	2013~2100y / 1~12 (Mon), 1~31 (Day) / 0~23h, 0~59m	2014 01.01. 0:00
	6CCC	Contacteur counter ^{note 2)}	-	-
	7FLt	Fault cause check ^{note 3)}	1. The most recent 2. The 2nd. recent 3. The 3rd. recent 4. The 4th. recent 5. The 5th. recent	-
	8A-r	Automatic reset time ^{note 4)}	OFF / 1~20m	Off
	9r-n	Automatic reset number Set number of times	Off/1-5	Off
	10Ad	Communication address ^{note 5)}	1~247	247
	11bs	Communication speed ^{note 5)}	9.6/19.2/38.4K	9.6K
	12SP	Swap ^{note 5)}	On/Off	Off
	13Pr	Parity setting ^{note 5)}	nonE/odd/EUEn	nonE
	14td	20mA setting ^{note 5)}	0.5~10/5~100	10/100
	rSt	Stored data deletion	All : for all subparameters trt : total running time CCC : contacteur counter CALo : calories FALt : fault events	-
	tEst	Operation test	o-L : overcurrent test g-F : ground fault test I-C : instantaneous test	-

Note) 1. When power is supplied for the first time or recovered after blackout, date information (5.S-d) should be set up to enter the year, month, date, hour and minute.

2. Switch count is counted up to 65,000, and it resets once it reaches the limit.

3. Up to 5 trip causes are saved, and the oldest data is overwritten when a new entry is saved.

4. Automatic recovery activates only in case of trip due to overload.

5. 10Ad, 11.bs, 12.SP, 13.Pr and 14.td can be set only at communication type product.

6. Data clear and Test can be normally inputted only during NORMAL, and TEST item can be checked only when the motor is ON.

Operation and Setting

4. Up & downloading of all settings once (Quick setup)

- 1) Press Up and Enter keys at the same time at the status of normal, MCC mode and motor stop, then "UPLd" begins to flash on the screen which denotes the setting values of the device are being uploaded in the display unit and "U.END" is displayed when completed. Press Enter key to return to the measurement screen.
- 2) After installing the uploaded display unit onto the device that is not set yet, press Down and Enter keys at the same time at the status of normal, MCC mode and motor stop, then "dnLd" begins to flash on the screen which denotes the setting values of the display unit are being downloaded in the device and "d.END" is displayed when completed. Press Enter key to return to the measurement screen.

Note) 1. Up & downloading is available between the same models. If the models are different each other an error occurs with "d.Err" message.
2. Up & downloading of date, running time and fault cause are not available.

5. Checking fault history

- 1) Press Esc and Enter keys at the same time in the measurement screen, then the most recent fault cause in #7 menu of D-group is displayed.
Note) If there is no fault history "1.non" is displayed.
- 2) Use Up and Down keys to move to the desired one out of 5 fault events and select by pressing Enter key.
- 3) The fault current of phase R is displayed. Each time pressing the down key following informations are displayed in turn :
fault current of phase S / fault current of phase T / overload ratio / date
- 4) To enter the previous mode, press Esc key.
- 5) Press Esc and Enter keys at the same time to return to the measurement screen.

6. Forced reset of thermal memory

Press Esc and Stop keys at the same time to make the tripped motor become a cold state by force when operating characteristic is set to inverse-time curve with thermal-memory (th).
If a motor is tripped due to overcurrent the immediate pressing of reset key at the hot state of the motor causes immediate tripping. To avoid it reset via pressing Esc and Stop keys at the same time which makes the motor cold state.

MMP-IR-10/100 Model

Before starting the motor, proceed as follows :

1. Connect the display unit to the main unit of the device and then turn on.

Verify that Power LED is switched on and the measurement screen is displayed.

- 1) Press and hold I-R Key and CHECK key simultaneously for 3 seconds to measure insulation resistance value of the motor. Insulation resistance is measured for 60 seconds and the measurement value is displayed.

Note) When the motor is operating, insulation resistance cannot be measured.

- 2) If TEMP key is pressed, temperature value measured is displayed.
- 3) When the device is booted up the measurement screen is display by default. Pressing Enter key allows to access the modes : Group → Menu → Setting value. Press Esc key to return to the previous mode.
Use Up & Down keys to change values in the screens of Measurement, Group, Menu, Setting. When the relay / alarm operates press Reset key to reset.

Note) refer to a manual for the details.

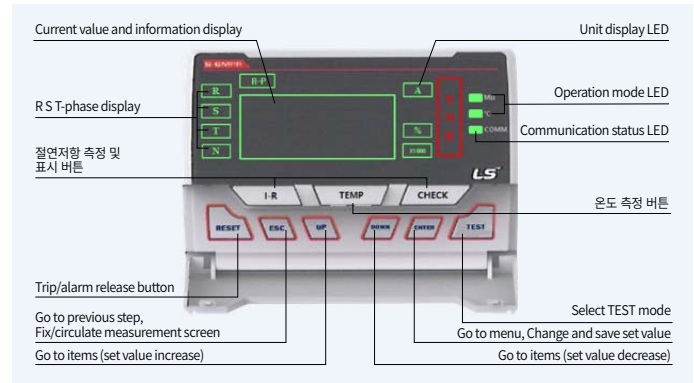

2. Verify the operations of Test key and Reset key through trip.

- 1) Verify the wiring first. Press Enter key to access Group menu, and use Up / Down keys to access B Group as shown "b-gr" and press Enter to access Menu with displaying "1.Loc". Use Up / Down keys to access "6.r-p" which denotes Phase reversal menu, and press Enter to access "CHEC" which denotes Setting value, and press Enter to view current wiring information.

Note) 1. The phase information is displayed only when current is applied. If there is no current "—" is displayed

- 2) If TEST key is pressed "E E E" appears at the screen and the device is Tripped.
- 3) Press Reset key to reset the device and return to the measurement screen.

Note) In the first access to change a parameter "P-99" for password input is displayed. Press Up key to change it to "P-00" and press Enter and then Setting change is allowed. If there is no input for 2 minutes it returns to the measurement screen.

3. Check the settings.

- 1) At normal state pressing Enter key access mode "A-gr" which enables setting. Select the desired group using the Up / Down keys and press Enter key to enter the desired group. To enter previous mode, press the Esc key.
- 2) The desired group displays from No. 1 menu. Select the desired menu using the Up / Down keys and press Enter key to enter the setting mode. To enter previous mode, press the Esc key.
- 3) Press Up / Down keys in the setting screen and then "P-99" is displayed. Press Up / Down keys to change the password to "P-00" and press Enter to release it. After that select the desired value and press Enter to save the setting.

Note) Enter the date exactly when the power is turned on for the first time or recovered after the outage.

Operation and Setting

Menu List (MMP-SB/SM-10/100)

A-group

Group	Menu	Description	Setting range	Default
A	1P/3P	Single-phase / 3-phase	1P/3P	3P
	25-F	Frequency	60	60
	3CH	Characteristics (Over Current Protection)	Off/dEF/th/n-th Note 1)	n-th
	40-t	Operating time	1~60sec (5/10/20/30/60)	60
	5d-t	Time Delay	1~200sec	200
	6r-c	Rated current (10, 100)	0.5~10/5~100	10
	7CTr	CT ratio	0.25/0.5/1~200 Note 2)	1
	8.1-r	Insulation resistance	n-c/Off/1/5/10/20	Off
	9tEP	Temperature	n-c/Off/50~150°C (1°C Step)	Off
	tCAL	Temperature compensation	0~50°C (1°C Step)	25

Note) 1. Operating characteristic th is the characteristic for thermal heat build-up type inverse time, and n-th is the characteristic for thermal heat non build-up type inverse time.
2. In case of 100A TYPE model, CT ratio is not indicated and fixed as 1.
3. Some menus are not displayed depending on function settings.

B-group

Group	Menu	Description	Setting range	Default	Remarks
B	1LoC	LOCK	Off/200~800%	Off	
	2StL	STALL	Off/150%~500%	Off	
	3P-F	Phasee loss (current)	On/Off	On	
	4P-U	Phasee unbalance (current)	Off/30~70%	Off	✓
	5PdE	Phasee loss / unbalance Time-delay	0~200sec	0	✓
	6r-P	Phase reversal (current)	Off/On/CHEC Note 1)	Off	✓
	7CrE	Phase reversal operation time	0.1~1.0sec	0.1	✓
	8U-C	Undercurrent	Off/30~90%	Off	✓
	9EcE	ZCT selection (PC mV, 1.5mA)	100/1.5 Note 2)	Enbd	
	10GF	Ground fault (Zero-phase)	Off/0.03/0.05/0.1~3.0	Off	
	11Gn	Ground fault (Residual current)	Off/30~100%	Off	
	12Gt	Ground fault operation time	0.05~3.0sec	3.0	✓
	13Gd	Ground fault Time-delay	0~200초	60	
	14IC	Instantaneous protection	Off/10A type: ~100A, 100A type: ~800A, 100A or more: using external CT Note 3)	Off	
	15AL	Output contact method	I-tp, I-AL, Alo, U-C, OrH, tEP, Ir, IrTE Note 4)	I-세	Refer to contact output information
	16Ar	Current Y / N, Alarm	On/60~110%	On	Refer to contact output information
17tH	THD (Voltage)	0~100%	Unit:%		

Note) 1. When CHEC set value of negative sequence item is selected, additional wire information is displayed.
2. ZCT selection is set depending on whether built in ZCT or external ZCT is used.
3. Tolerance guarantee scope for 10A type: ~100A/100A type: 600A for 50Hz, 720A for 60Hz
4. I-tp: Instantaneous trip, Circuit breaker trip (interlocked), I-AL: Instantaneous alarm, Alo: Current alarm setting, U-C: When low current factor works, OrH: When continuous motor operating hour is over the set value, tEP: Alarm when temperature is over the set value, Ir: Alarm when the value is below insulation resistance value set, IrTE: Alarm when temperature is over the set value or insulation resistance is below the set value.
5. Menu 16 is displayed only when "Alo" is set at menu 15.

Contact output information

15.AL setting	Output condition	Alarm output type	
		Motor operation	07-08
I-tp	Detection of instantaneous current	Motor stop	NC
I-AL	Detection of instantaneous current	Maintain status	NC
U-C	Detection of current carrying below low current set value	Maintain status	NC
OrH	Operating time setting and output	Maintain status	NC
Alo	Select 18.Ar setting	Follows setting at item 16	
tEP	Exceeding set temperature	Maintain status	NC
lr	Detection of insulation resistance below set value	Maintain status	NC
lrtE	In case of irregularity with temperature or insulation resistance	Maintain status	NC
16.Ar setting	In case Alo is set at item 15	Motor operation	07-08
On	Output of current carrying (>0A) status	Maintain status	NC
60~110%	Current carrying of over the set value	Maintain status	NC

C-group

Group	Menu	Description	Setting range	Default
C	1trt	Total operating hour	0~9999day/0~23hr/0~59min	-
	2r-t	Operating hour	0~9999hr	-
			0~59min	
	3sr-t	Setting of operating hour	Off/10~8760	Off
	4S-d	Date setting ^{Note1)}	2019~2100	2019
			1~12Month, 1~31f day	01.01.
			0~23hr, 0~59min	0:00
	5FLt	Checking reason of failure	-	-
	6Ar-r	Automatic recovery ^{Note2)}	Off/1~20min	Off
	7r-n	Restriction of restart	Off/1~5	Off
	8Ad	Communication address	1~247	247
	9bS	Communication speed	9.6/19.2/38.4K	9.6K
	10SP	Swap or not	On/Off	Off
	11Pr	Parity setting	nonE/odd/EUEn	nonE
12td	Setting of 20mA	0.5~10/5~100	10/100	
rSt	Deleting stored data ^{Note3)}	All the lower level items	-	
		trt : Total operating hour		
		CALo : Heat quantity		
		FALt : Failure event		

Note) 1. In case power was supplied for the first time or recovered after blackout, date information (5S-d) should be set up to enter the year, month, date, hour and minute.

2. Automatic recovery activates only in case of trip due to overload.

3. Data clear can be inputted normally only during NORMAL.

Operation and Setting

4. Up & downloading of all settings once (Quick setup)

- 1) When Up key and Enter key are pressed at the same time in the normal status or motor STOP status, “UpLd” blinks at screen and set value of main body is saved at display, and “U.End” is displayed after completion of saving. At this time, if Enter Key is pressed for confirmation, screen returns to measurement mode.
- 2) If Down key and Enter key are pressed at the same time in the normal status or motor STOP status, “dnLd” blinks at screen and set value of display is saved at main body, and “d.End” is displayed after completion of downloading. At this time, if Enter Key is pressed for confirmation, screen returns to measurement mode

Note) 1. Up & downloading is available between the same models. If the models are different each other an error occurs with "d.Err" message.
2. Up & downloading of date, running time and fault cause are not available.

5. Checking fault history

- 1) Press Esc and Enter keys at the same time in the measurement screen, then the most recent fault cause in #7 menu of D-group is displayed.
Note) If there is no fault history "1.non" is displayed.
- 2) Use Up and Down keys to move to the desired one out of 5 fault events and select by pressing Enter key.
- 3) The fault current of phase R is displayed. Each time pressing the down key following informations are displayed in turn :
fault current of phase S / fault current of phase T / overload ratio / date
- 4) To enter the previous mode, press Esc key.
- 5) Press Esc and Enter keys at the same time to return to the measurement screen.

6. Forced reset of thermal memory

Press Esc and CHECK keys at the same time to make the tripped motor become a cold state by force when operating characteristic is set to inverse-time curve with thermal-memory (th).
If a motor is tripped due to overcurrent the immediate pressing of reset key at the hot state of the motor causes immediate tripping.
To avoid it reset via pressing Esc and CHECK keys at the same time which makes the motor cold state.

Fault cause information

	Screen	Fault cause	Additional information
Current	<code>O-L</code>	Overcurrent	phase, load rate, time
	<code>Loc</code>	Lock	phase, load rate, time
	<code>StL</code>	Stall	phase, load rate, time
	<code>P-F</code>	Phasee loss	phase, unbalance rate, time
	<code>P-U</code>	Phasee unbalance	phase, unbalance rate, time
	<code>r-P</code>	Phase reversal	time
	<code>U-C</code>	Undercurrent	phase, load rate, time
	<code>Sho</code>	Instantaneous	phase, load rate, time
	<code>g-F</code>	Ground fault (ZCT)	phase and neutral, time
	<code>g-n</code>	Ground fault (Residual)	phase and neutral, time
Voltage	<code>O-U</code>	Overvoltage	phase, rate, time
	<code>U-U</code>	Undervoltage	phase, rate, time
	<code>uPF</code>	Phasee loss	phase, unbalance rate, time
	<code>uPU</code>	Phasee unbalance	phase, unbalance rate, time
	<code>urP</code>	Phase reversal	time
Voltage	<code>O-P</code>	Overpower	phase voltage, rate, time
	<code>U-P</code>	Underpower	phase voltage, rate, time
	<code>OPF</code>	Over power factor	phase voltage, rate, time
	<code>UPF</code>	Under power factor	phase voltage, rate, time
Others	<code>ETP</code>	External input trip	time
	<code>Err.1</code>	Error.1 occured	Current detected after motor off
	<code>Err.2</code>	Error.2 occured	No current detected after motor on
	<code>Err.3</code>	Error.3 occured	For / Rev starting signal input at the same time in local / auto mode
	<code>Err.4</code>	Error.4 occured	External storage memory error
	<code>OrH</code>	Running hour over	Alarm occurs when accumulated running hour is over the setting value
	<code>tAP</code>	Temperature over the set degree	
	<code>uIr</code>	In case insulation resistance below set value is measured	
	<code>AcOn</code>	In case measurement of insulation resistance is attempted during operation	
	<code>LInE</code>	Display comm. error	Comm. error occur between display unit and device. ※ Please contact us.
Ex)	<code>10 10</code>	Version check	Press Reset+Esc keys in normal state

Terminal configuration / Wiring & cable connection

Terminal configuration (S-EMPR MMP-PM)

Terminals	Description	Remarks
Va, Vb, Vc	Voltage input	Current model Blank
Z1, Z2	ZCT input	Universal (Z1, Z2 : 1.5mA) Z2V, Z1V Dedicated (Z2V, Z1V : 100mV)
Z2V, Z1V		
4~20mA (+), (-)	4~20mA output	-
TRX1+, TRX1- TRX2+, TRX2-	RS485 communication	Modbus(1 channel)
A1, A2	Control power input	110Vac or 220Vac 50/60Hz
C1	Contact input Common	-
Lop/Stop, For, Rev, Res, E/S	Contact input	RES : Reset, E/S: Emergency Stop
C2	Relay output Common	-
Main, Y, D, Auto, Volt	Relay output	D: Delta, VOLT : output contacts for voltage & power elements
C3	Relay output Common	Aux output Common
Aux	Relay output	Current element output contacts

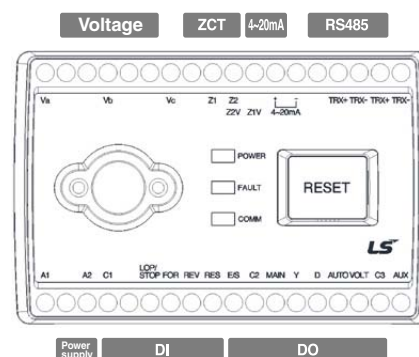

Terminal configuration (S-EMPR MMP-CM)

Terminals	Description	Remarks	
A1, A2	Operating power input terminal	110Vac or 220Vac 50/60Hz	
C1	Contact point in put common	Lop/Stop, For, Rev, Res, E/S contact point	
Lop/Stop	Lop operation mode selection and external stop S/W	-	
For	External On(Forward) input S/W	On input in Lop/Auto operation	
Rev	Reverse input S/W in forward/reverse starting	REV input in Lop/Auto operation	
Res	External Reset S/W	Reset input in Lop operation	
E/S	External Emergency Stop S/W	-	
C2	Contact point output common	Main, Y, D, Auto contact point	
Main	Motor On output	If forward/backward starting, forward rotation output	
	Y-Delta starting: Y contact point output	-	
	Inverter starting: Inverter contact point output	-	
	Full voltage starting: No use	-	
Y	Forward/backward starting: No use	-	
	Reactor starting: No use	-	
	D	Y-Delta starting: Delta contact point output	-
		Forward/backward starting: reverse rotation contact point output	-
Reactor starting: Reactor (R) contact point output		-	
Inverter starting: Bypass contact point output		-	
Auto	Full voltage starting: No use	-	
	Auto state signal output	If Auto state mode is selected	
C3	Contact point output common	Aux contact point only	
Aux	Current factors contact point output	-	
Z1, Z2	Zero current transformer output connection terminal	Universal ZCT(200mA/1.5mA)	
Z1V, Z2V	Zero current transformer output connection terminal	ZCT(200mA/100mV)	
+, -	4~20mA output	-	
TRX+, TRX-	RS485terminal	-	

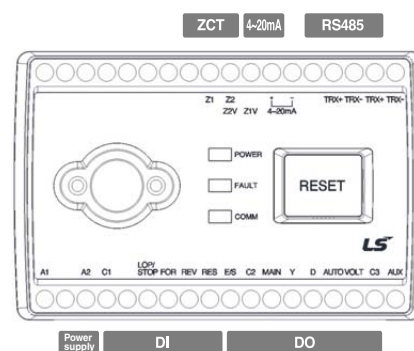

Terminal configuration (S-EMPR MMP-SM)

Terminals	Description	Remarks
A1, A2	Operating power input terminal	110Vac or 220Vac 50/60Hz
C1	Contact point in put common	Lop/Stop, For, Rev, Res, E/S contact point
Lop/Stop	Lop operation mode selection and external stop S/W	-
For	External On(Forward) input S/W	On input in Lop/Auto operation
Rev	Reverse input S/W in forward/reverse starting	REV input in Lop/Auto operation
Res	External Reset S/W	Reset input in Lop operation
E/S	External Emergency Stop S/W	-
C2	Contact point output common	Main, Y, D, Auto contact point
Main	Motor On output	If forward/backward staring, forward rotation output
Y	Y-Delta starting: Y contact point output	-
	Inverter starting: Inverter contact point output	-
	Full voltage starting: No use	-
	Forward/backward staring: No use	-
	Reactor starting: No use	-
D	Y-Delta starting: Delta contact point output	-
	Forward/backward staring: reverse rotation contact point output	-
	Reactor starting: Reactor (R) contact point output	-
	Inverter starting: Bypass contact point output	-
	Full voltage starting: No use	-
Auto	Auto state signal output	If Auto state mode is selected
Volt	Ground fault overvoltage factors and current trip contact point output	-
C3	Contact point output common	Aux contact point only
AUX	Other current factors contact point output	-
Vo+, Vo-	Zero voltage input	-
Z1, Z2	Zero current transformer output connection terminal	Universal ZCT(200mA/1.5mA)
+, -	4~20mA output	-
TRX+, TRX-	RS485terminal	-

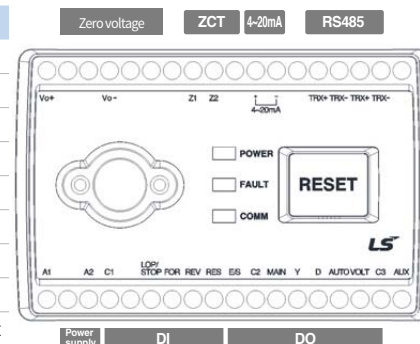

*Attention in panel design

1. It is required to have grounding connection with all equipment.
2. It is required to minimize wiring as most as possible.
3. After a shield-type cable is applied, it is required to ground the shield.

*If induced voltage occurs

1. It is required to add a proper capacitor in parallel depending on the parasitic capacitance of product input part.
2. If induced voltage occurs even after the capacitor is added, it is required to get auxiliary relay energized in order for an input to make possible through an auxiliary contact point when a circuit is designed.

Terminal configuration (S-EMPR MMP-IR)

Terminals	Description	Remarks
A1, A2	Operating power input terminal	110Vac 60Hz
L, E	Terminal for insulation resistance measurement	Lop/Stop, For, Rev, Res, E/S contact point
DI	M/C status input terminal	110Vac 60Hz
95-96	In case of Power On (NC contact output terminal), (NO contact output terminal)	
97-98	In case of Power On (NC contact output terminal), (NO contact output terminal)	
07-08	Output of Instantaneous, Low current and Other alarm	
A-B	Temperature sensor input connection terminal	
Z1-Z2	Zero current transformer output connection terminal	ZCT(200mA/100mV)
+, -	4~20mA output	
TRX+, TRX-	RS485terminal	

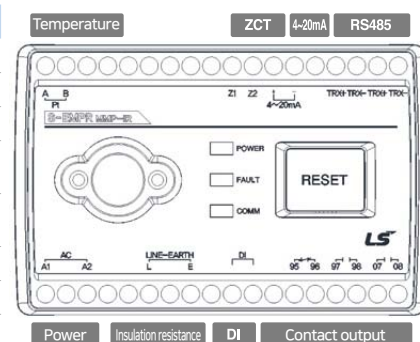

Terminal configuration / Wiring & cable connection

Full voltage start

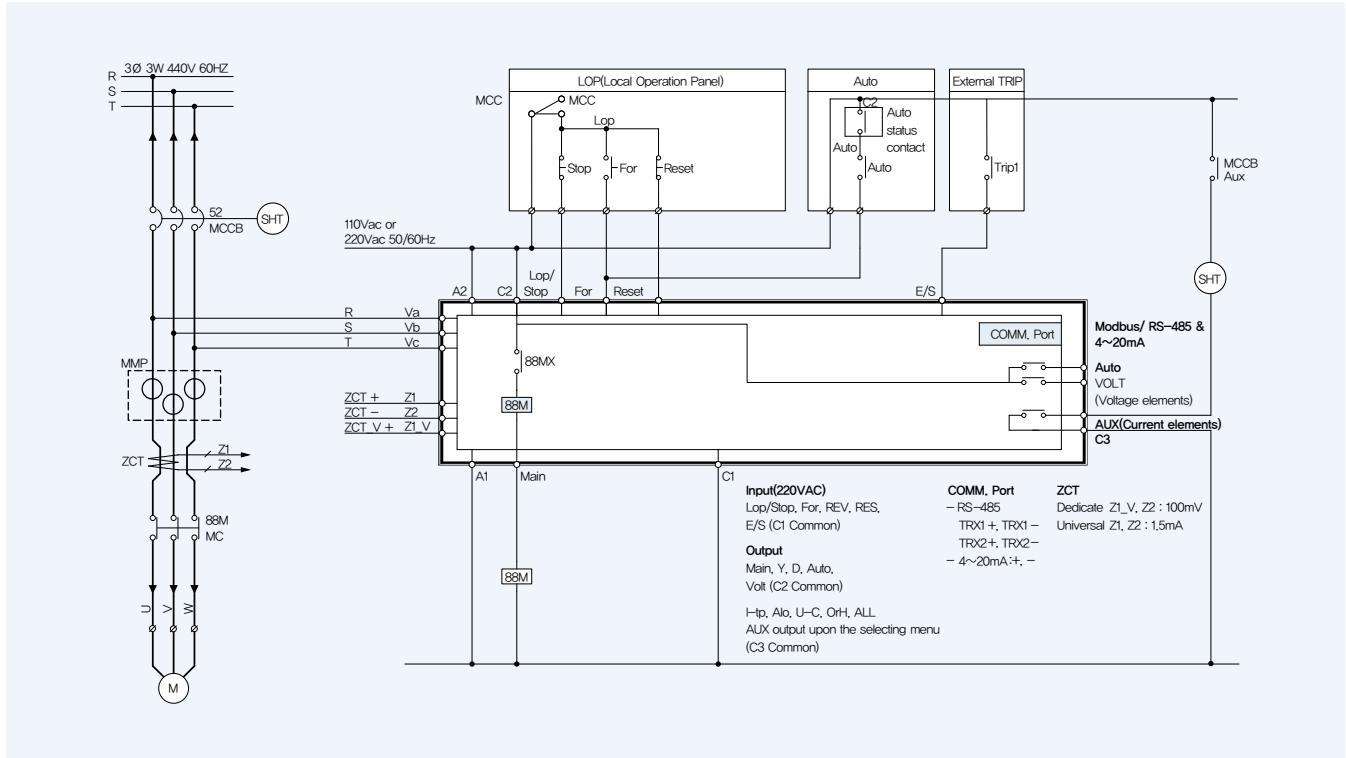

Note) In case of distance operation (LOP / AUTO), if a wiring distance is too long, induced voltage can cause malfunction. Therefore, bear in mind this point at the time of designing a panel.

Reversible operation

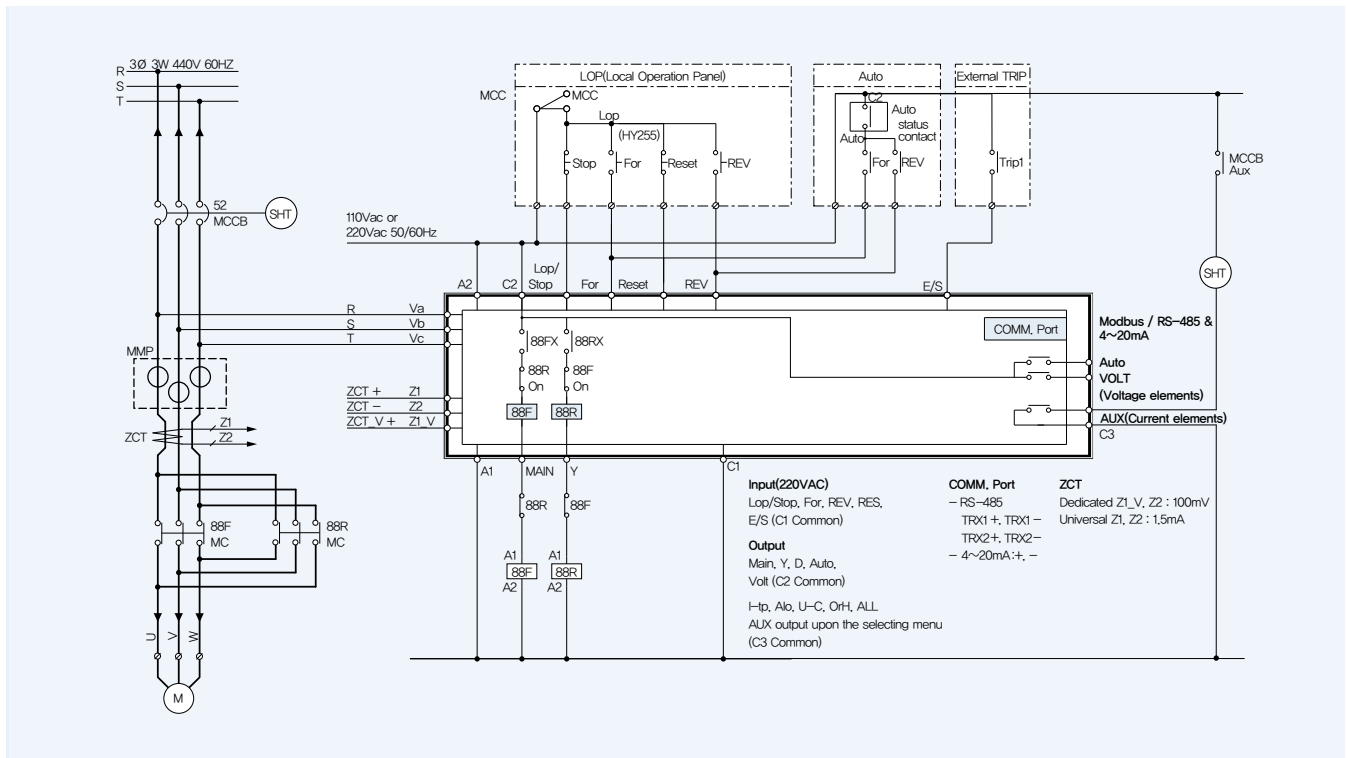

Y-D start

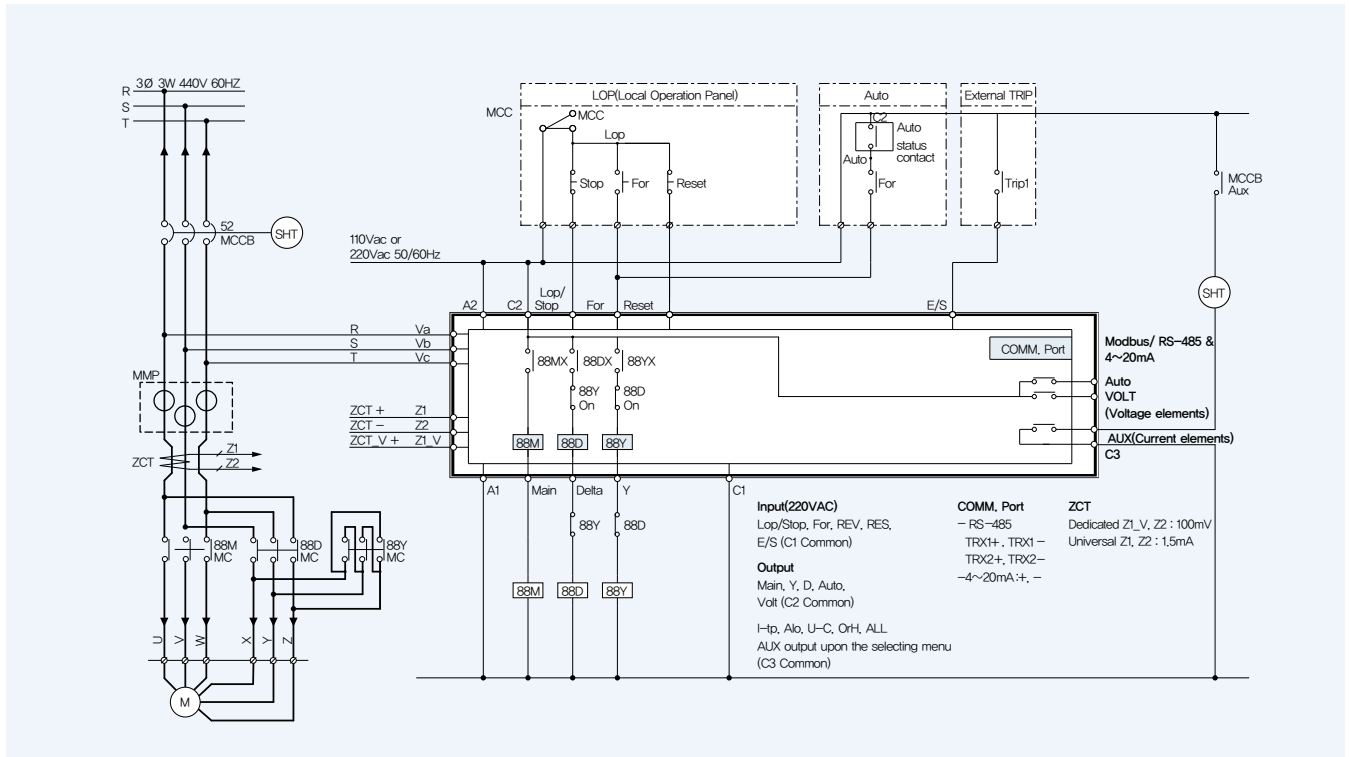

Reactor start

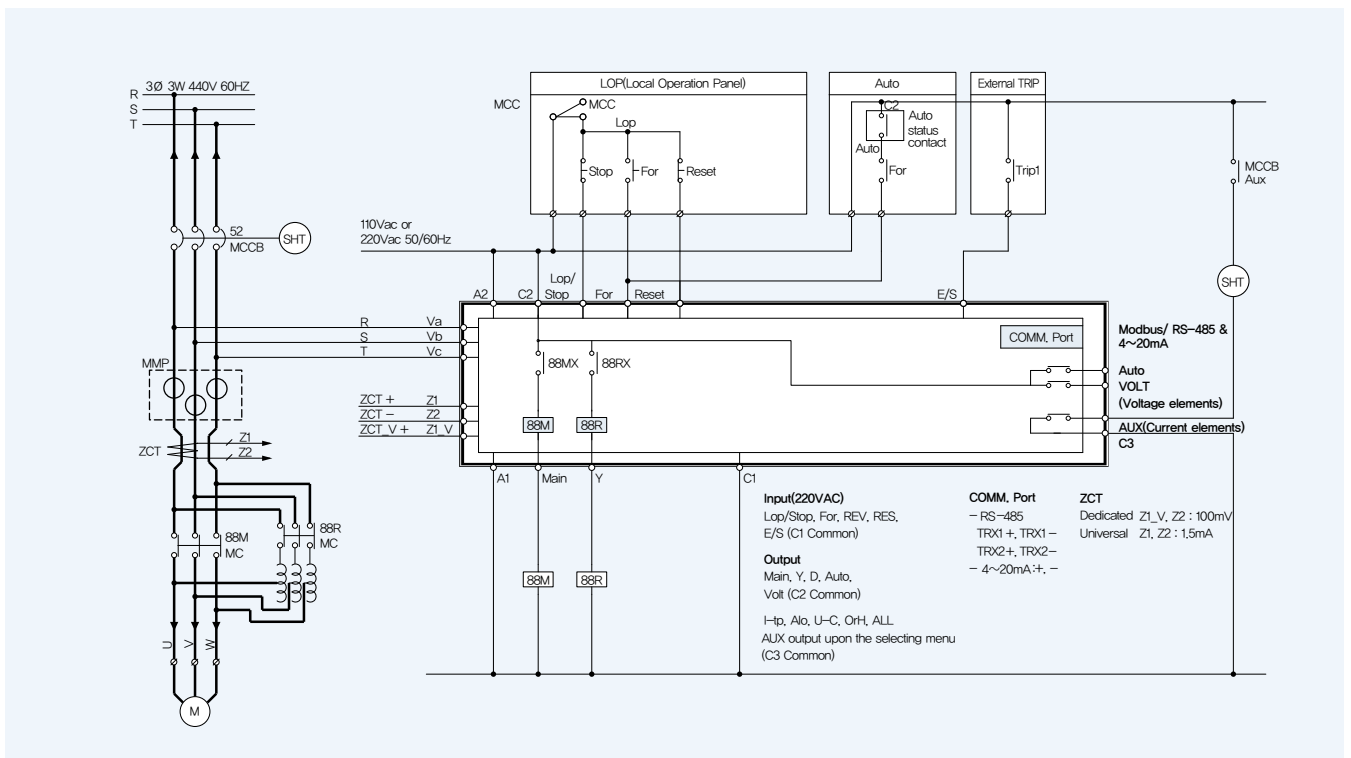

Terminal configuration / Wiring & cable connection

Irreversible full voltage starting

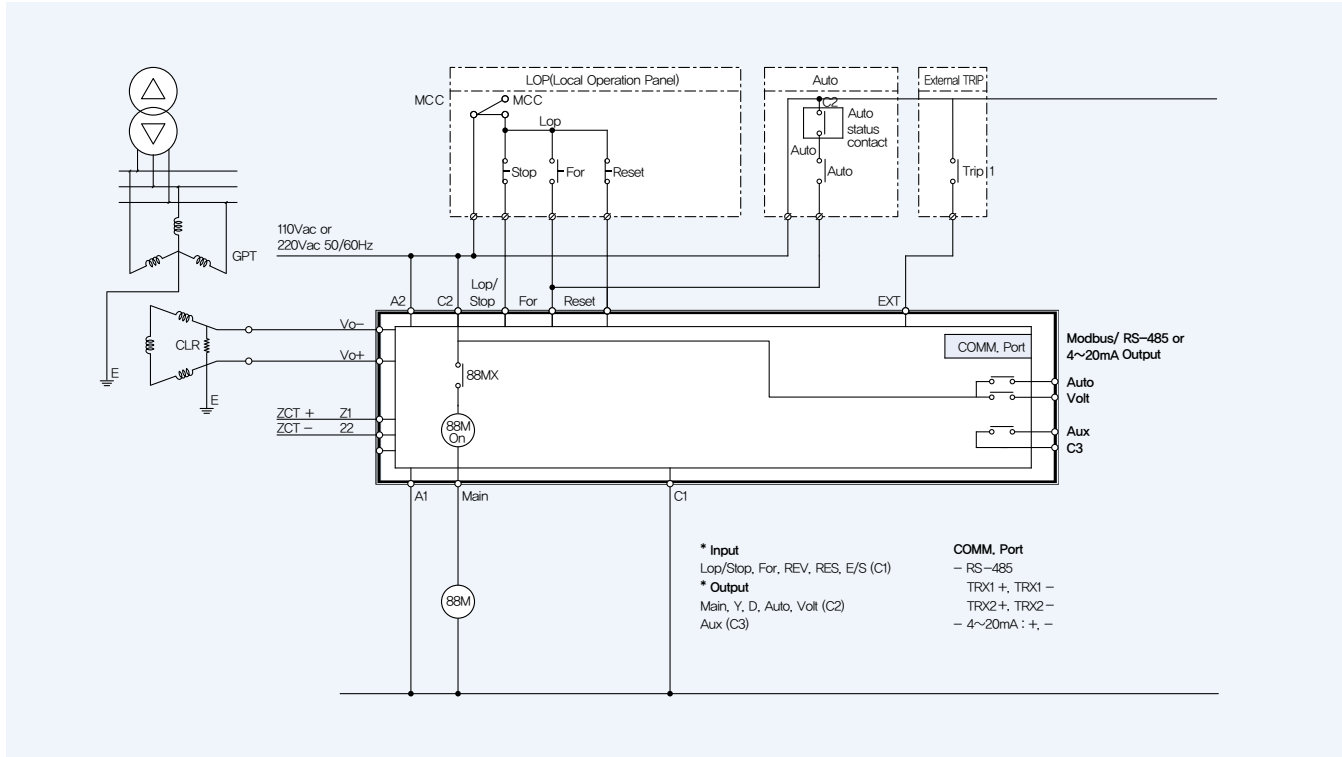

Reversible full voltage starting

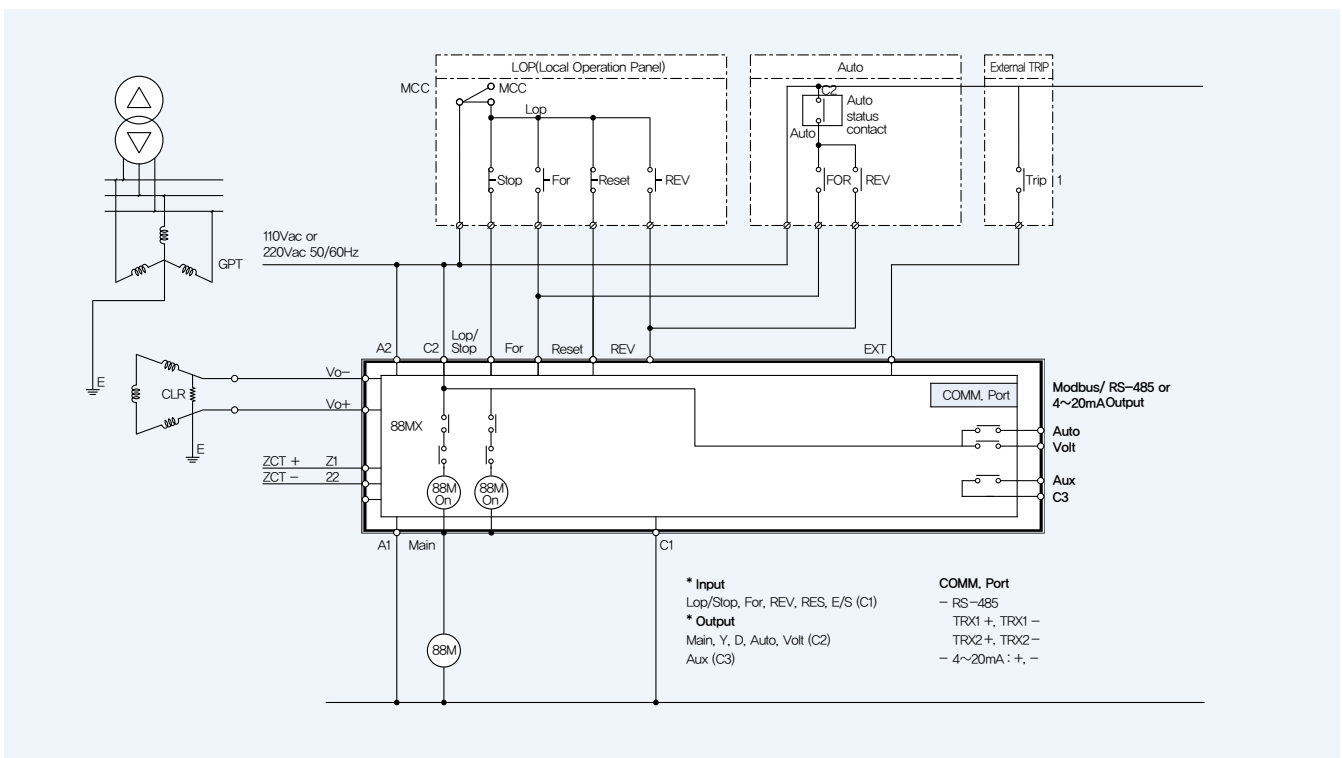

Inverter start (Current)

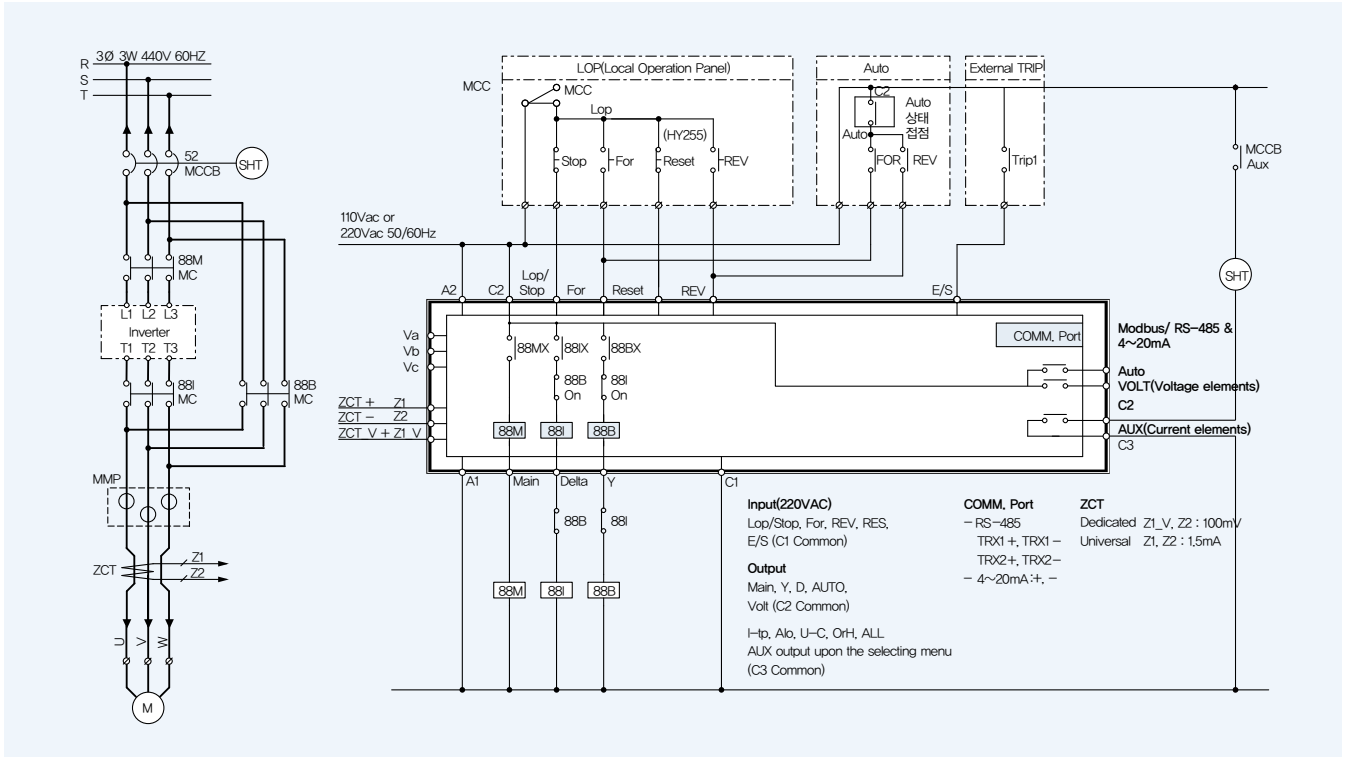

Soft starter start

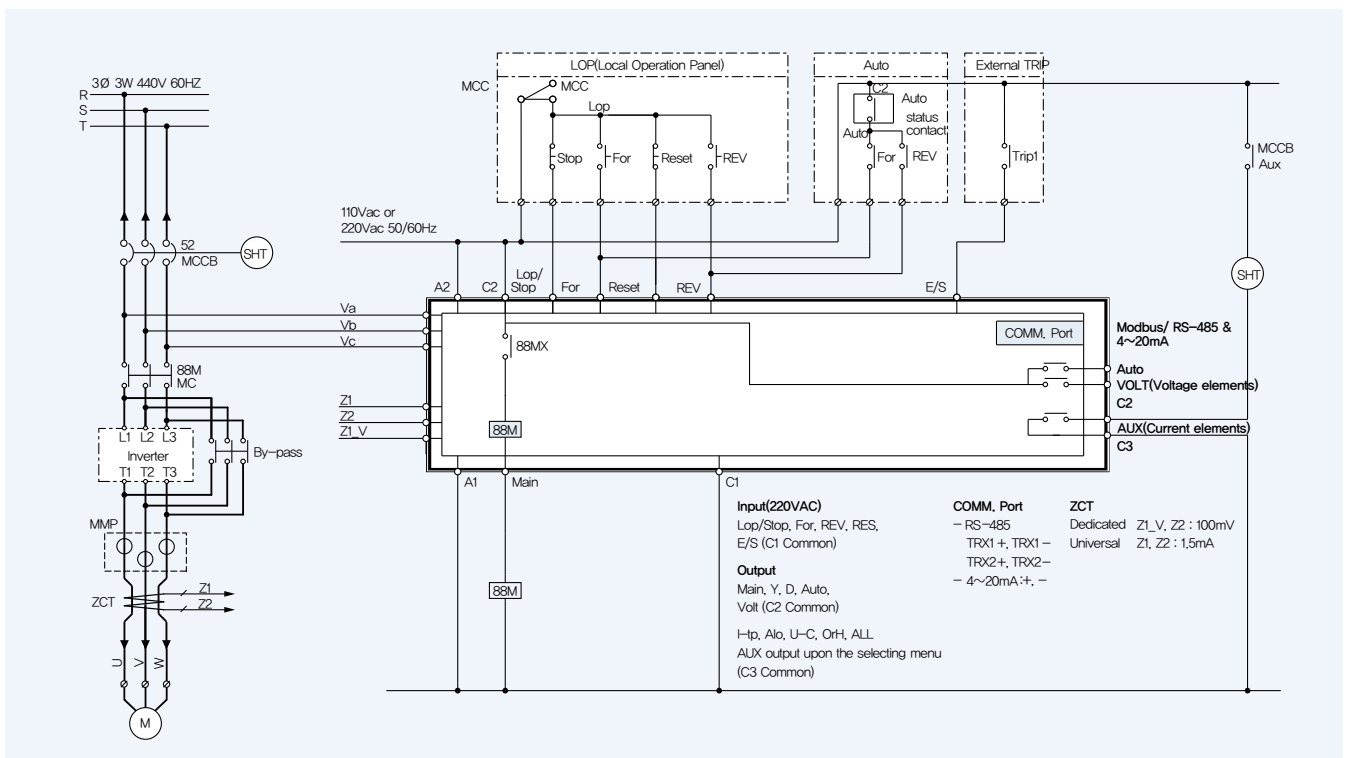

Wiring & cable connection / Dimensions

MMP-IR TYPE

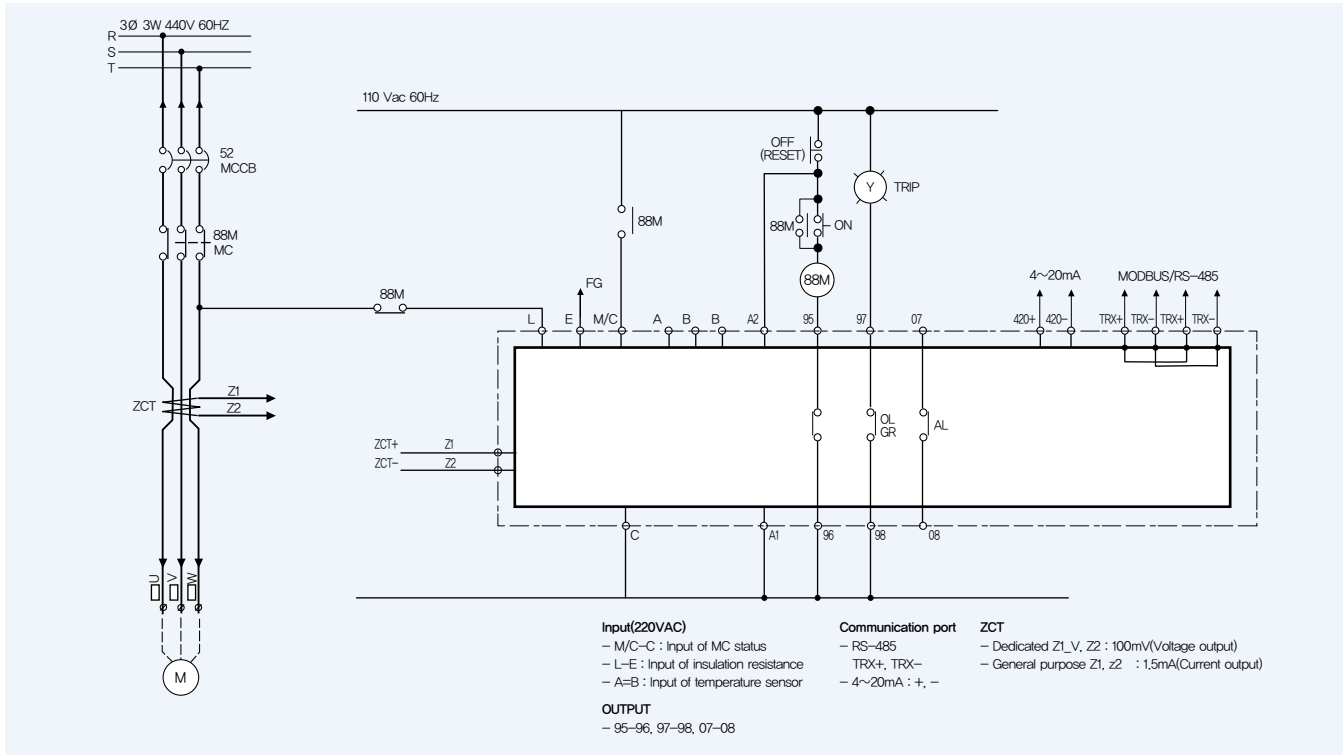

Note) IR model does not support start mode.

Dimensions

Unit : mm

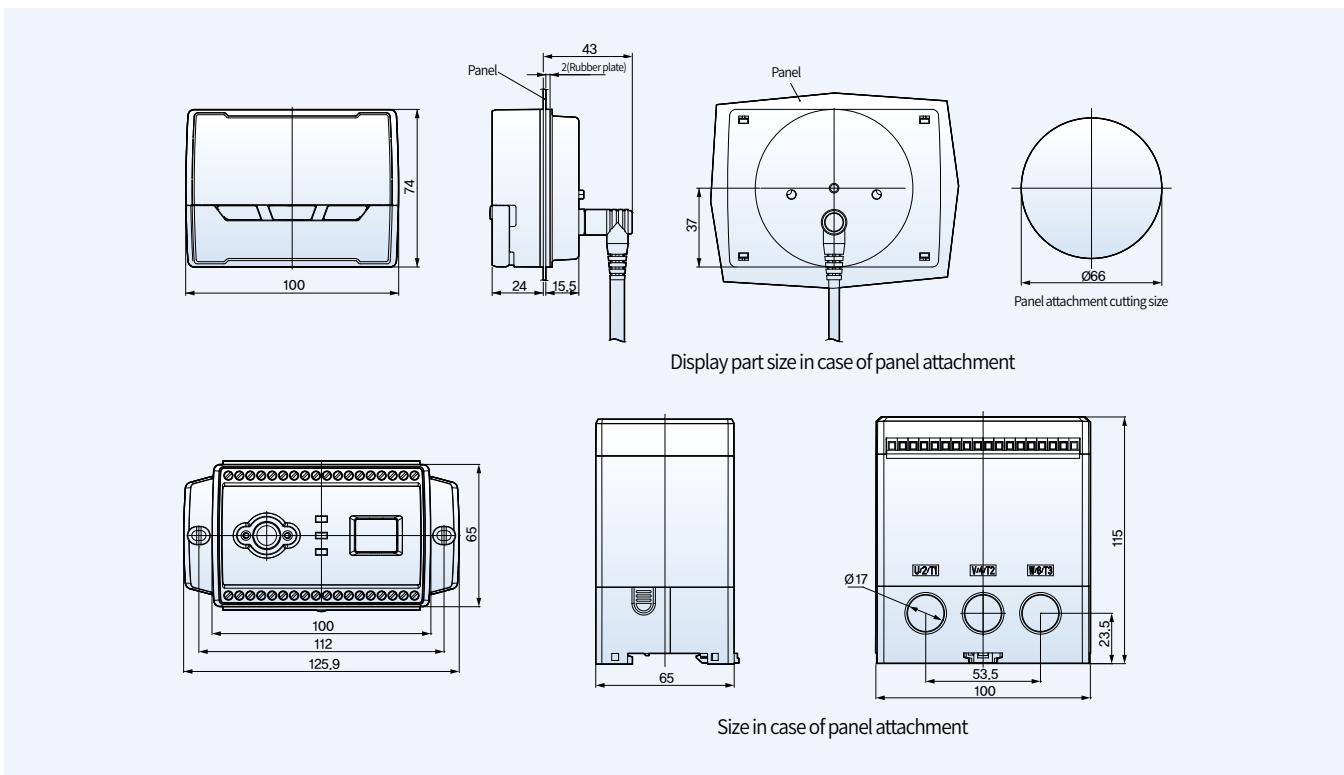

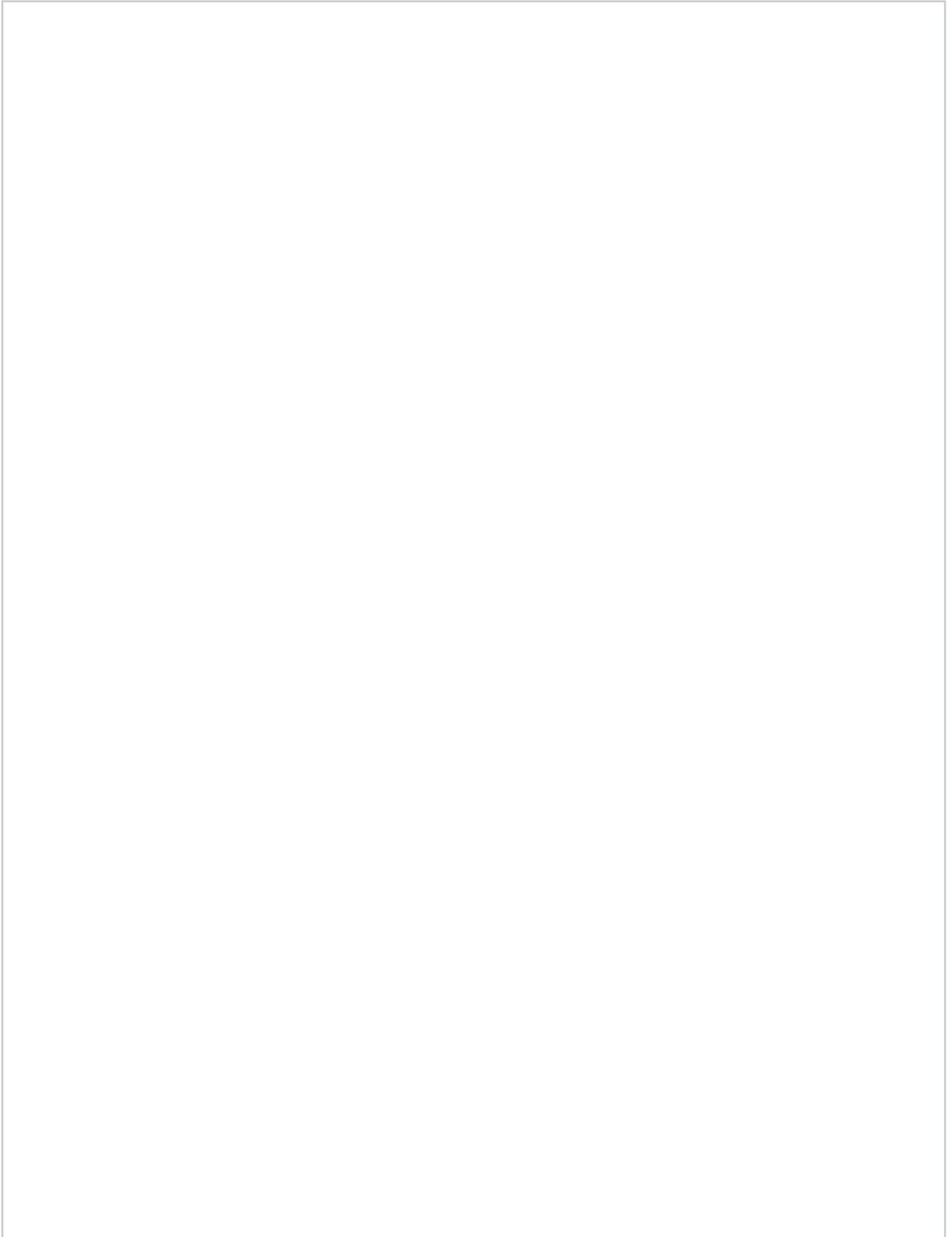



Safety Instructions

- For your safety, please read user's manual thoroughly before operating.
- Contact the nearest authorized service facility for examination, repair, or adjustment.
- Please contact qualified service technician when you need maintenance. Do not disassemble or repair by yourself!
- Any maintenance and inspection shall be performed by the personnel having expertise concerned.



- According to The WEEE Directive, please do not discard the device with your household waste.



www.lselectric.co.kr

■ **Headquaters**

127, LS-ro(hogye-dong) Dongan-gu, Anyang-si, Gyeonggi-Do, 14119, Korea

■ **Seoul Office**

LS Yongsan Tower, 92, Hangang-daero, Yongsan-gu, Seoul, 04386, Korea
Tel: 82-2-2034-4916, 4684, 4429

■ **Overseas Subsidiaries**

- **LS ELECTRIC Japan Co., Ltd. (Tokyo, Japan)**
Tel: 81-3-6268-8241 E-Mail: jschuna@lselectric.biz
- **LS ELECTRIC (Dalian) Co., Ltd. (Dalian, China)**
Tel: 86-411-8730-5872 E-Mail: jiheo@lselectric.com.cn
- **LS ELECTRIC (Wuxi) Co., Ltd. (Wuxi, China)**
Tel: 86-510-6851-6666 E-Mail: jdyim@lselectric.com.cn
- **LS ELECTRIC Vietnam Co., Ltd.**
Tel: 84-93-631-4099 E-Mail: jhchoi4@lselectric.biz (Hanoi)
Tel: 84-28-3823-7890 E-Mail: sjbaik@lselectric.biz (Hochiminh)
- **LS ELECTRIC Middle East FZE (Dubai, U.A.E.)**
Tel: 971-4-886-5360 E-Mail: hschoib@lselectric.biz
- **LS ELECTRIC Europe B.V. (Hoofddorf, Netherlands)**
Tel: 31-20-654-1424 E-Mail: europartner@lselectric.biz
- **LS ELECTRIC America Inc. (Chicago, USA)**
Tel: 1-800-891-2941 E-Mail: sales.us@lselectricamerica.com

■ **Overseas Branches**

- **LS ELECTRIC Tokyo Office (Japan)**
Tel: 81-3-6268-8241 E-Mail: jschuna@lselectric.biz
- **LS ELECTRIC Beijing Office (China)**
Tel: 86-10-5095-1631 E-Mail: chendm@lselectric.com.cn
- **LS ELECTRIC Shanghai Office (China)**
Tel: 86-21-5237-9977 E-Mail: khpaek@lselectric.com.cn
- **LS ELECTRIC Guangzhou Office (China)**
Tel: 86-20-3818-2883 E-Mail: chenxs@lselectric.com.cn
- **LS ELECTRIC Chengdu Office (China)**
Tel: 86-28-8670-3201 E-Mail: yangcf@lselectric.com.cn
- **LS ELECTRIC Qingdao Office (China)**
Tel: 86-532-8501-2065 E-Mail: wangzy@lselectric.com.cn
- **LS ELECTRIC Nanjing Office (China)**
Tel: 86-25-8467-0005 E-Mail: ylong@lselectric.com.cn
- **LS ELECTRIC Bangkok Office (Thailand)**
Tel: 66-90-950-9683 E-Mail: sjleet@lselectric.biz
- **LS ELECTRIC Jakarta Office (Indonesia)**
Tel: 62-21-2933-7614 E-Mail: dioh@lselectric.biz
- **LS ELECTRIC Moscow Office (Russia)**
Tel: 7-499-682-6130 E-Mail: jdpark1@lselectric.biz
- **LS ELECTRIC America Western Office (Irvine, USA)**
Tel: 1-949-333-3140 E-Mail: ywyun@lselectricamerica.com



Technical Question or After-sales Service

Customer Center-Quick Responsive Service, Excellent technical support

82-1644-5481