

GMP Series

Electronic Motor Protection Relays

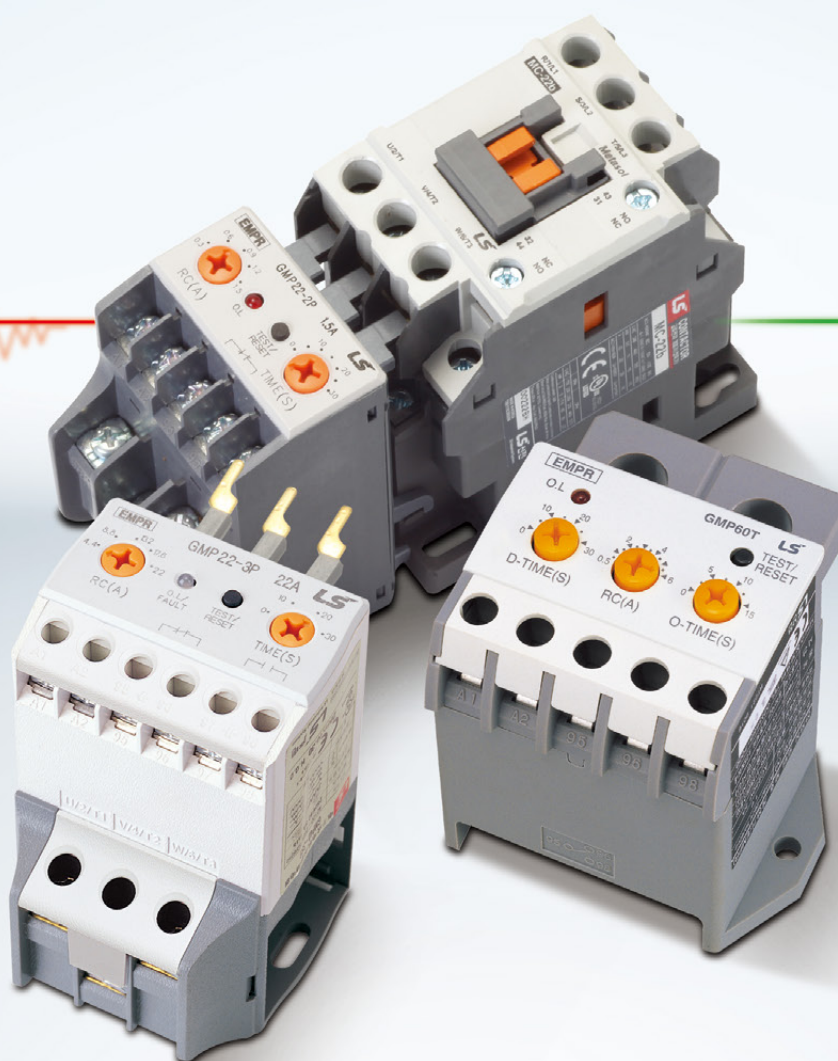

The new standard of next-generation motor protection relay!

With smart protection and safe control, we provide the cutting-edge digital total solution.

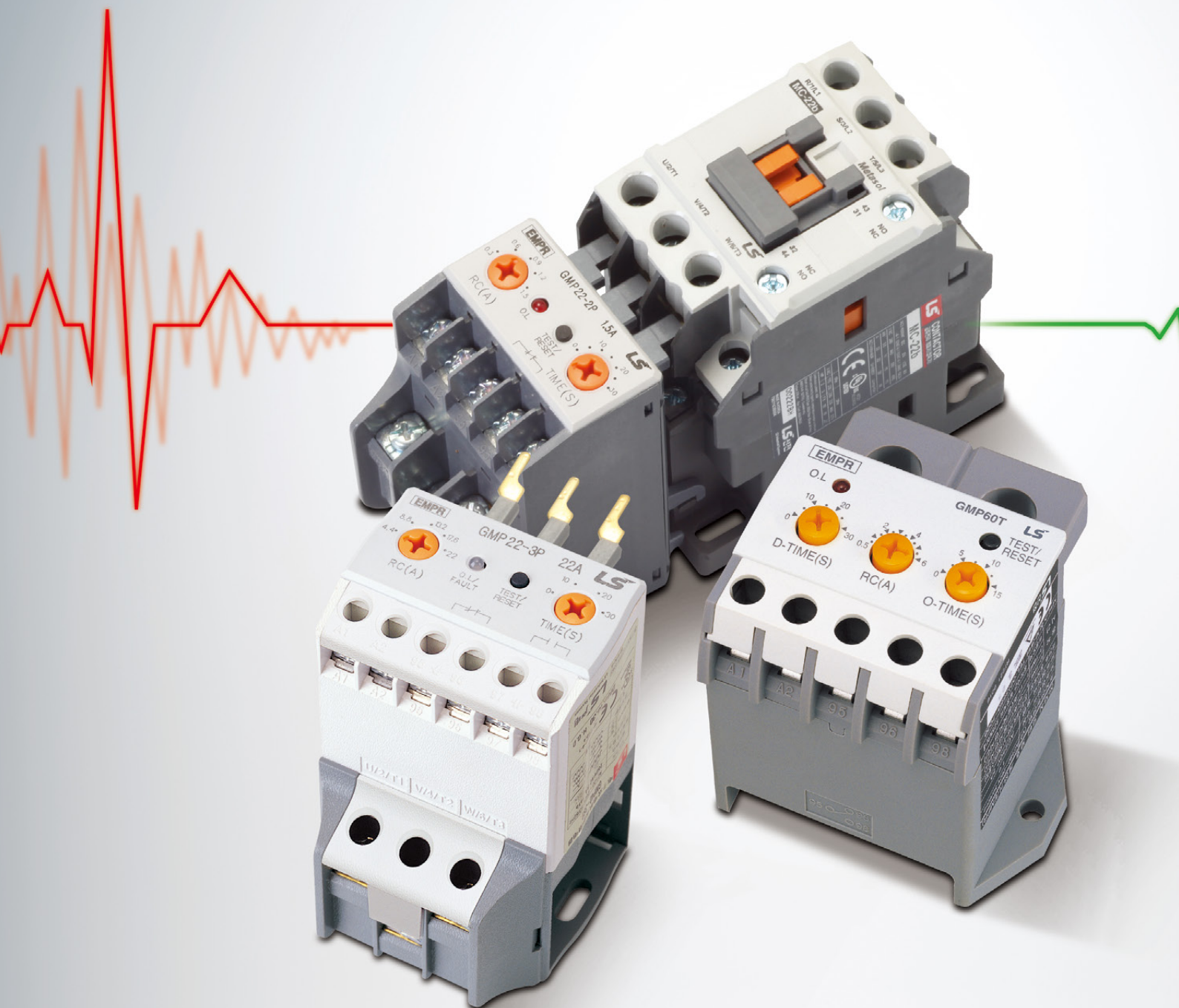

GMP Series

Electronic Motor Protection Relays

- Definite/inverse time protection of a variety of rating
- Ground fault protection model
- LED based display of failure cause
- MC direct coupling, penetration, and terminal types sharing



Contents

- 04 A list of standard models
- 05 Product characteristics
- 06 Rated specifications / Order type
- 15 Motor selection / Model numbering system
- 16 Operation & setting method
- 21 Terminal configuration / Wiring & cable connection
- 24 Dimensions

A list of standard models



Rated current	Connection method	Type name	over-current	Locked rotor	Phase failure	Phase unbalance	Reverse phase	low current	Ground Fault	Characteristic
0.3~1.5 1~5 4.4~22A	Pin type <small>note 1)</small>	GMP22-2P Sol	●	●	●	-	-	-	-	Inverse time
		GMP22-2PD Sol	●	●	●	-	-	-	-	Definite time
		GMP22-2P Sol	●	●	●	-	-	-	-	Inverse time
		GMP22-2PA Sol	●	●	●	-	-	-	-	Definite time/ Automatic return
	Screw type	GMP22-3P Sol	●	●	●	●	-	-	-	Inverse time
		GMP22-3PR Sol	●	●	●	●	●	-	-	Inverse time
		GMP22-2S	●	●	●	-	-	-	-	Inverse time
		GMP22-3S	●	●	●	●	-	-	-	Inverse time
		GMP22-3SR	●	●	●	●	●	-	-	Inverse time
		Tunnel types	GMP22-2T	●	●	●	-	-	-	-
	GMP22-3T		●	●	●	●	-	-	-	Inverse time
	GMP22-3TR		●	●	●	●	●	-	-	Inverse time
4~20 8~40A	Pin type <small>note 1)</small>	GMP40-2PD Sol	●	●	●	-	-	-	-	Definite time
		GMP40-2P Sol	●	●	●	-	-	-	-	Inverse time
		GMP40-2PA Sol	●	●	●	-	-	-	-	Inverse time/ Automatic return
		GMP40-3P Sol	●	●	●	●	-	-	-	Inverse time
	Screw type	GMP40-3PR Sol	●	●	●	●	●	-	-	Inverse time
		GMP40-2S	●	●	●	-	-	-	-	Inverse time
		GMP40-3S	●	●	●	●	-	-	-	Inverse time
	Tunnel types	GMP40-3SR	●	●	●	●	●	-	-	Inverse time
		GMP40-2T	●	●	●	-	-	-	-	Inverse time
		GMP40-3T	●	●	●	●	-	-	-	Inverse time
		GMP40-3TR	●	●	●	●	●	-	-	Inverse time
		0.5~6 3~30 5~60A	Tunnel types	GMP60T	●	●	●	-	-	-
GMP60TE	●			●	●	-	-	-	-	Inverse time
GMP60TA	●			●	●	-	-	-	-	Definite time/ Automatic return
GMP60TD	●			●	●	-	-	-	-	Definite time
0.5~60A		GMP60TDa	●	●	●	-	-	●	-	Definite time/ Automatic return
0.5~60A	Tunnel types	GMP60-3T	●	●	●	●	-	-	-	Definite time
		GMP60-3TR	●	●	●	●	●	-	-	Definite time
		GMP60-3TZ <small>※2)</small>	●	●	●	●	-	-	●	Definite time
		GMP60-3TN	●	●	●	●	-	-	●	Definite time
		GMP60-3TZR	●	●	●	●	●	-	●	Definite time
		GMP60-3TNR	●	●	●	●	●	-	●	Definite time
0.5~60A <small>※3)</small>	Screw type	GMP60-3S	●	●	●	●	-	-	-	Definite time
		GMP60-3SR	●	●	●	●	●	-	-	Definite time
		GMP60-3SZ	●	●	●	●	-	-	●	Definite time
		GMP60-3SN	●	●	●	●	-	-	●	Definite time
		GMP60-3SZR	●	●	●	●	●	-	●	Definite time
		GMP60-3SNR	●	●	●	●	●	-	●	Definite time
16~80A	Screw type	GMP80-2S	●	●	●	-	-	-	-	Inverse time
		GMP80-2SA	●	●	●	-	-	-	-	Inverse time/ Automatic return
		GMP80-3S	●	●	●	●	-	-	-	Inverse time
		GMP80-3SR	●	●	●	●	●	-	-	Inverse time
		GMP80-3SR	●	●	●	●	●	-	-	Inverse time

Note) 1. Direct coupling type (Pin) supports direct coupling of Metasol MC. With your order, it is required to describe "Sol".

2. For GMP60-3TZ/3TZR, use ZCT (100mA/40~55mV) for EMPR only.

3. In case of GMP60-3S Series, it is required to purchase a terminal block separately.

4. This product is designed for protecting a low-voltage motor with 1,000V or less. Therefore, it should not be used in high voltage lines.

Convenience



Integrated Digital Motor Protection Relay using MCU(Microprocessor Control Unit)

It offers real time data processing and high precision.



Applicable to inverter circuits

It may be applied to the secondary inverter control circuit with its outstanding resistance to harmonic noise. (Usable frequency range: 20~200Hz, except for phase reversal model)



Save the last fault cause

At the time of power recover after power failure, it is possible to check the final operation cause. (Test/Reset Key 2-time operation)Limited to GMP60-3T Series only



Sharing of terminal contact type and penetration type

It is possible to detach and attach a terminal block and conveniently apply the product to a variety of installation conditions.



Perfect connection with LS Digital Contactor Metasol MC

EMPR	Contactor model
GMP22-2P/3P/3PR	MC-9b, MC-12b, MC-18b, MC-22
GMP40-2P/3P/3PR	MC-32a, MC-40a

*In case of Metasol MC direct coupling type, it is required to describe "Sol" with your order.
*GMP80-Model is unable to direct-couple to Metasol MC.



Various Installation Ways

With the uses of screws and brackets for DIN-Rail, it is possible to install 35mm DIN-Rail.



Wide Current Control Range

Since this product has a wide current control range, it is more convenient than thermal overload relays.

Reliability



Acquired S-Mark (safety certification) first in the industry

What is S-Mark (safety)?

S-Mark is used to approve a product's safety, reliability, and safe design manufacturing in the way of reviewing the quality management system of its manufacturer. If a product complies with safety certification standards, it has safety certification (S-Mark). 'S-Mark (see Mark)' is applied to a product, a product package, or a product advertisement in order to show its safety.



Remarkable improvement in the characteristics of Noise

- This product solves the malfunction made by electromagnetic waves and surges which are the biggest problem of digital motor protection relays.
- With the application of highly-reliable Toroidal CT, the product safely protects digital contactors, radio devices, lightning surges, impulses, etc. against external influence.



Inverse time characteristic good for motor protection

Thanks to the inverse time characteristic in which a running time is determined by a size of overcurrent, the product is excellent at motor protection.

Rated specifications / Order type

GMP22-2P, 2PD 1c



GMP22-2P(1c)
GMP22-2PD(1c)

Specification (Direct type EMPR)

Connection: Accessible electronic contactors	Minimum direct connection with width 44mm : MC-9b, 12b, 18b, 22b
Auxiliary contact	1SPDT 1c (N type) ^{note1}
Current setting range	0.3~1.5/1~5/4.4~22A
Operating time characteristics	Inverse time, Definite time (PD)
Number of built-in CT (deflector)	2 (R, T phase)
Operating power	AC 110/220V (±10%)
Return (reset) method/time	Manual/Electrical return
Using Inverter Secondary	Available

Type	GMP22-2P (1c) Sol	GMP22-2PD (1c) Sol
Protection		
Overcurrent	✓	✓
Lock/Stall	✓	✓
Phase failure	✓ ^{note 2}	✓ ^{note 2}
Certification	UL, CE	✓

Contactor
MC-9b, 12b, 18b, 22b



Contactor
Direct
connection



Order type

Type	Model/CT	Operating characteristics	Current setting range	Order type	
Pin type	GMP22-2P(1c) -2CT type	Inverse time (0~30sec)		0.3 - 1.5A	GMP22-2P(1c) 1.5A Sol
				1 - 5A	GMP22-2P(1c) 5A Sol
				4.4 - 22A	GMP22-2P(1c) 22A Sol
				0.3 - 1.5A	GMP22-2P(1c) 1.5A [N]
				1 - 5A	GMP22-2P(1c) 5A [N]
				4.4 - 22A	GMP22-2P(1c) 22A [N]
				0.3 - 1.5A	GMP22-2P(1c) 1.5A [R]
	1 - 5A	GMP22-2P(1c) 5A [R]			
	4.4 - 22A	GMP22-2P(1c) 22A [R]			
	GMP22-2PD(1c) -2CT type	Definite time D-Time : 0~60sec O-Time : 5sec(Fixed)		0.3 - 1.5A	GMP22-2PD(1c) 1.5A Sol
				1 - 5A	GMP22-2PD(1c) 5A Sol
				4.4 - 22A	GMP22-2PD(1c) 22A Sol
				0.3 - 1.5A	GMP22-2PD(1c) 1.5A [N]
				1 - 5A	GMP22-2PD(1c) 5A [N]
4.4 - 22A				GMP22-2PD(1c) 22A [N]	
0.3 - 1.5A				GMP22-2PD(1c) 1.5A [R]	
1 - 5A	GMP22-2PD(1c) 5A [R]				
4.4 - 22A	GMP22-2PD(1c) 22A [R]				

Note 1. 1c contacts have two types of products: N-type (Fail Safe/Normal Energied) and R-type(Non Fail Safe / Normal De-Energied). In terms of product reliability, N-type (Fail Safe) product is recommended to be used.

2. The product detects phase failure of the phase (R, T) connected with two CTs in order for protection.

Technical information

Installation	Direct connection to contactors (not alone)
Tolerance	Current : ±5% Time : ±5% (or±0.5sec)
Frequency	50/60Hz
Aux. contact Ratings	5A/250VAC Resistive load
Insulation resistance	Min 100MΩ at 500Vdc
Lightning impulse voltage	1.2×50μs 5kV With standard waveform (IEC1000-4-5)
Fast Transient Burst	2kV/5min (IEC1000-4-4)
Environment	Operation : -25~70°C Storage : -30~80°C Relative humidity : within 80% RH, no condensation
Trip indicator	Red LED
Application specification	UL508, IEC60947-1



GMP22-□



Pin type
GMP22-□P, PR



Screw type
GMP22-□S, SR



Tunnel type
GMP22-□T, TR

Specification

Various connection methods : Electronic contactors applied	Pin, Screw, Tunnel type : MC-9b, 12b, 18b, 22b
Auxiliary contact	2SPST (1a1b at energization)
Current setting range	0.3~1.5/1~5/4.4~22A
Operating time characteristics	Inverse time
Number of built-in CT (deflector)	2 (R, Tphase) or 3
Operating power	AC 100~260V
Return (reset) method/time	Manual/Electrical return (Standard) Manual/Auto/Electrical return (2PA)
Using Inverter Secondary	Available (Exclude GMP22-3PR, 3TR, 3SR)

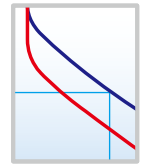





Inverse time

*GMP22-2PA automatically returns within 60 seconds in case of overcurrent.

Type (GMP22-□)	2P, 2PA, 2T, 2S	3P, 3T, 3S	3PR, 3TR, 3SR
Overcurrent	✓	✓	✓
Lock/Stall	✓ (note)	✓	✓
Phase failure	✓	✓	✓
Phase unbalance	-	✓	✓
Reverse phase	-	-	✓
Certification	UL, CE	✓ (Exclude 2PD)	✓

(Note) The product detects phase failure of the phase (R, T) connected with two CTs in order for protection.

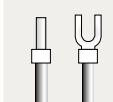
Order type

Mounting type	Model/CT	Current setting range	Order type
Direct mount onto a Metasol MC  Electronic contactor MC-9b, 12b, 18b, 22b 	GMP22-2P (1a1b) - 2CT type	0.3 - 1.5A	GMP22-2P(1a1b) 1.5A Sol
		1 - 5A	GMP22-2P(1a1b) 5A Sol
		4.4 - 22A	GMP22-2P(1a1b) 22A Sol
	GMP22-2PA (1a1b) - 2CT type - Automatic return	0.3 - 1.5A	GMP22-2PA(1a1b) 1.5A Sol
		1-5A	GMP22-2PA(1a1b) 5A Sol
		4.4-22A	GMP22-2PA(1a1b) 22A Sol
	GMP22-3P - 3CT type	0.3 - 1.5A	GMP22-3P 1.5A Sol
		1 - 5A	GMP22-3P 5A Sol
		4.4 - 22A	GMP22-3P 22A Sol
	GMP22-3PR - 3CT type - Reverse phase protection	0.3 - 1.5A	GMP22-3PR 1.5A Sol
		1 - 5A	GMP22-3PR 5A Sol
		4.4 - 22A	GMP22-3PR 22A Sol
Screw type  Install Screw/Rail 	GMP22-2S - 2CT type	0.3 - 1.5A	GMP22-2S 1.5A
		1 - 5A	GMP22-2S 5A
		4.4 - 22A	GMP22-2S 22A
	GMP22-3S - 3CT type	0.3 - 1.5A	GMP22-3S 1.5A
		1-5A	GMP22-3S 5A
		4.4-22A	GMP22-3S 22A
	GMP22-3SR - 3CT type - Reverse phase protection	0.3 - 1.5A	GMP22-3SR 1.5A
		1 - 5A	GMP22-3SR 5A
		4.4 - 22A	GMP22-3SR 22A
Tunnel type  Install Screw/Rail	GMP22-2T - 2CT type	0.3 - 1.5A	GMP22-2T 1.5A
		1 - 5A	GMP22-2T 5A
		4.4 - 22A	GMP22-2T 22A
	GMP22-3T - 3CT type	0.3 - 1.5A	GMP22-3T 1.5A
		1-5A	GMP22-3T 5A
		4.4-22A	GMP22-3T 22A
	GMP22-3TR - 3CT type - Reverse phase protection	0.3 - 1.5A	GMP22-3TR 1.5A
		1 - 5A	GMP22-3TR 5A
		4.4 - 22A	GMP22-3TR 22A

Rated specifications / Order type

GMP40-□



Pin type
GMP40-□P, PR



Screw type
GMP40-□S, SR



Tunnel type
GMP40-□T, TR

Specification

Various connection methods : Electronic contactors applied	Pin, Screw, Tunnel type : MC-32a, 40a
Auxiliary contact	2SPST (1a1b at energization)
Current setting range	4~20/8~40A
Operating time characteristics	Inverse time, Definite time (2PD)
Number of built-in CT (deflector)	2 (R, T phase) or 3
Operating power	AC 100~260V
Return (reset) method/time	Manual/Electrical return (Standard) Manual/Auto/Electrical return (2PA)
Using Inverter Secondary	Available (Exclude GMP40-3PR, 3TR, 3SR)

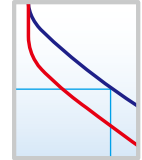





Inverse time

*GMP40-2PA automatically returns within 60 seconds in case of overcurrent.

Type (GMP22-□)	2P, 2PD, 2PA, 2T, 2S	3P, 3T, 3S	3PR, 3TR, 3SR
Overcurrent	✓	✓	✓
Lock/Stall	✓	✓	✓
Phase failure	✓ <i>note</i>	✓	✓
Phase unbalance	-	✓	✓
Reverse phase	-	-	✓
Certification	UL, CE	✓ (Exclude PD, PA)	✓

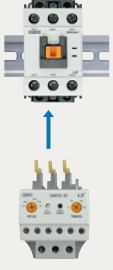
Note) The product detects phase failure of the phase (R, T) connected with two CTs in order for protection.

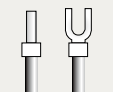
Order type

Mounting type	Model/CT	Current setting range	Order type	
Direct mount onto a Metasol MC 	GMP40-2P - 2CT type	4 - 20A	GMP40-2P 20A Sol	
		8 - 40A	GMP40-2P 40A Sol	
	GMP40-2PA - 2CT type - Automatic return	4-20A	GMP40-2PA 20A Sol	
		8-40A	GMP40-2PA 40A Sol	
	GMP40-2PD - 2CT type - Defined Time characteristics	4-20A	GMP40-2PD 20A Sol	
		8-40A	GMP40-2PD 40A Sol	
	GMP40-3P - 3CT type	4 - 20A	GMP40-3P 20A Sol	
		8 - 40A	GMP40-3P 40A Sol	
	GMP40-3PR - 3CT type - Reverse phase protection	4 - 20A	GMP40-3PR 20A Sol	
		8 - 40A	GMP40-3PR 40A Sol	
	Screw type  	GMP40-2S - 2CT type	4 - 20A	GMP40-2S 20A
			8 - 40A	GMP40-2S 40A
GMP40-3S - 3CT type		4 - 20A	GMP40-3S 20A	
		8 - 40A	GMP40-3S 40A	
GMP40-3SR - 3CT type - Reverse phase protection		4 - 20A	GMP40-3SR 20A	
		8 - 40A	GMP40-3SR 40A	
Tunnel type 	GMP40-2T - 2CT type	4 - 20A	GMP40-2T 20A	
		8 - 40A	GMP40-2T 40A	
	GMP40-3T - 3CT type	4 - 20A	GMP40-3T 20A	
		8 - 40A	GMP40-3T 40A	
	GMP40-3TR - 3CT type - Reverse phase protection	4 - 20A	GMP40-3TR 20A	
		8 - 40A	GMP40-3TR 40A	

GMP22/40-□



GMP22



GMP40

Front face configuration

Current setting	
GMP22	GMP40
0.3 - 1.5A	4 - 20A
1 - 5A	8 - 40A
4.4 - 22A	-

LED	
2CT type : Red LED	
3CT type : 2 colors LED (Red/Green)	
Operation status indication	Trip cause indication
normal	Overcurrent
Overcurrent	Phase failure
Phase unbalance (3CT)	Reverse phase (3CT)

Operation time adjustment dial
0~30sec (Class 5-10-20-30)
Set the operating time of inverse time characteristic
Set time is the trip time at 6x set current

*GMP22/40-2PD has the characteristic of definite time.

Sharing of installation and contact

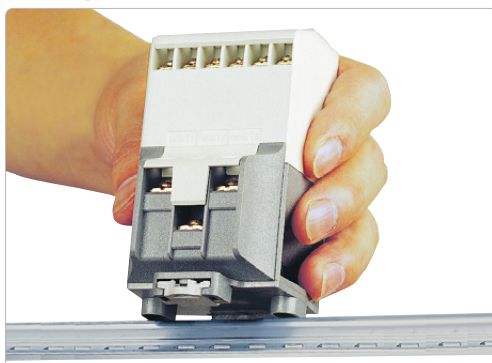

Screw installation ↔ Rail installation sharing
Terminal connection type and penetration type have the common use structure of DIN rail and screw installation.



Terminal connection type ↔ penetration type sharing
If the terminal block of terminal connection type is removed, it is possible to make a penetration type

Technical information

Tolerance	Current : ±5% Time : ±5% (or ±0.5sec)
Frequency	50/60Hz
Aux. contact Ratings	5A/250VAC Resistive load
Insulation resistance	Minimum 100MΩ/500VDC
Lightning impulse voltage	1.2×50μs 5kV With standard waveform (IEC60255-22-5)
Fast Transient Burst	2kV/1min (IEC61000-4-4)
Environment	Operation : -25~70°C Storage : -30~80°C Relative humidity : within 80% RH, no condensation
Trip indicator	2CT : Red LED, 3CT : Red/Green 2 colors LED
Application specification	IEC60947-1

Rated specifications / Order type

GMP60T



GMP60T

Specification (Tunnel type /Economic type EMPR)

Connection methods	Tunnel type
Auxiliary contact	1SPDT 1c (N type) <i>note 1)</i>
Current setting range	0.5~6/3~30/5~60A
Operating time characteristics	Definite time
Number of built-in CT (deflector)	2 (R, T type)
Operating power	AC24V/48V/110V/220V/380V(440) AC180~480V AC110V/220V (GMP60TA)
Return (reset) method/time	Manual/Electrical return (Standard) Manual/Auto/Electrical return (60TA)
Using Inverter Secondary	Available



Definite time

Type (GMP22-□)		GMP60T	GMP60TE	GMP60TA
Protection	Overcurrent	✓	✓	✓
	Lock/Stall	✓	✓	✓
	Phase failure	✓ <i>note 2)</i>	✓ <i>note 2)</i>	✓ <i>note 2)</i>
Operation time setting		0~30sec	5sec (Fixed)	5sec (Fixed)
Auto-return setting		-	-	0~120sec
Certification	UL, CE	✓	✓	-

Note 1. 1c contacts have two types of products: N-type (Fail Safe/Normal Energied) and R-type(Non Fail Safe / Normal De-Energied). In terms of product reliability, N-type (Fail Safe) product is recommended to be used

2. The product detects phase failure of the phase (R, T) connected with two CTs in order for protection.

Order type

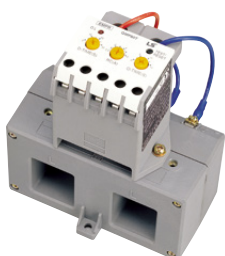

If external CT (current transformer) is used, the product is applicable to a large current of 60A or more.

Mounting type	Model/CT	Operating characteristics	Current setting range	Order type
Pin type	GMP60T - 2CT type	Defined Time characteristics D-Time : 0~30sec O-Time : 0~15sec	0.5 - 6A	GMP60T 6A
			3 - 30A	GMP60T 30A
			5 - 60A	GMP60T 60A
	GMP60TE - 2CT type - Economic type	Defined Time characteristics D-Time : 0~30sec O-Time : 5sec (Fixed)	0.5 - 6A	GMP60TE 6A
			3 - 30A	GMP60TE 30A
			5 - 60A	GMP60TE 60A
	GMP60TA - 2CT type - Auto-return	Defined Time characteristics D-Time : 0~30sec O-Time : 5sec (Fixed) A-Time : 0~120sec	0.5 - 6A	GMP60TA 6A
			3 - 30A	GMP60TA 30A
			5 - 60A	GMP60TA 60A

*Auto Reset: applicable only at Overcurrent Trip

Technical information

Install	Screw / rail mounting
Tolerance	Current : ±5% Time : ±5% (or ±0.5sec)
Frequency	50/60Hz
Aux. contact Ratings	5A/250VAC Resistive load
Insulation resistance	Minimum 100MΩ/500VDC
Lightning impulse voltage	1.2×50μs 5kV With standard waveform (IEC60255-22-5)
Fast Transient Burst	2kV/1min (IEC61000-4-4)
Environment	Operation : -25~70°C Storage : -30~80°C Relative humidity : within 80% RH, no condensation
Trip indicator	Red LED
Application specification	IEC60947-1

GMP6-TD, TDa



GMP6-TD
GMP6-TDa

Specification (Tunnel type/3-phase current indication type EMPR)

Connection methods	Tunnel type
Auxiliary contact	2SPST (1a1b at energization)
Current setting range	0.5~60A
Current Ratio	0.25, 0.5, 1~120 (0.125~600A)
Operating time characteristics	Definite time
Number of built-in CT (deflector)	2 (R, T type)
Operating power	AC 110V/220V (Separate)
Return (reset) method/time	Manual (GMP6-TD) Manual/Auto (GMP6-TDa)
Using Inverter Secondary	Available

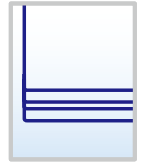

Definite time

Type	GMP6-TD	GMP6-TDa
Protection	Overcurrent	✓
	Lock/Stall	✓
	Phase failure	✓ <i>note)</i>
	Low current	✓
Auto-return setting	-	✓
Operation time setting	-	✓
Save the last fault cause	-	✓

Note) The product detects phase failure of the phase (R, T) connected with two CTs in order for protection.



Current control range by
Rated Current Setting DIP S/W:
0.5A~60A

Order type

Mounting type	Model/CT	Operating characteristics	Current setting range	Order type
Tunnel type Screw / rail mounting	GMP6-TD - 2CT type	Defined Time characteristics D-Time : 1~60sec O-Time : 0.5~30sec	0.5 - 60A	GMP6-TD 6/60A
	GMP6-TDa - 2CT type - Low Current Protection - Auto-return	Defined Time characteristics D-Time : 1~60sec O-Time : 0.5~30sec A-Time : 1~20min	0.5 - 60A	GMP6-TDa 6/60A

Technical information

Install	Screw / rail mounting
Tolerance	Current : $\pm 5\%$ Time : $\pm 5\%$ (or $\pm 0.5\text{sec}$)
Frequency	50/60Hz
Aux. contact Ratings	5A/250VAC Resistive load
Insulation resistance	Minimum 100M Ω /500VDC
Lightning impulse voltage	1.2 \times 50 μ s 5kV With standard waveform
Fast Transient Burst	2kV/1min
Environment	Operation : -25~70°C Storage : -30~80°C Relative humidity : within 80% RH, no condensation
Trip indicator	7-Segment, 3-phase current value, trip cause
Application specification	IEC60947-1

Rated specifications / Order type

GMP60-3T/3TR, 3S/3SR



GMP60-3T
GMP60-3TR

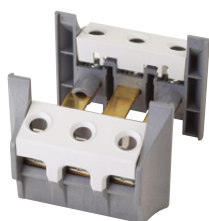

Terminal Block

Specification (Tunnel type / Screw type EMPR)

Connection methods	Tunnel type / Screw type
Auxiliary contact	2SPST (1a1b at energization)
Current setting range	0.5~60A
Operating time characteristics	Definite time
Number of built-in CT (deflector)	3
Operating power	AC 100~260V
Return (reset) method/time	Manual/Electrical return
Using Inverter Secondary	Available (Exclude GMP60-3TR)



Definite time

Type	GMP60-3T, 3S	GMP60-3TR, 3SR
Overcurrent	✓	✓
Lock/Stall	✓	✓
Phase failure	✓	✓
Phase unbalance	✓	✓
Reverse phase	-	✓
Save the last fault cause	✓	✓

* To use a terminal connection type (Screw Type), please purchase a terminal block separately.

Order type

Mounting type	Model/CT	Operating characteristics	Current setting range	Order type
Tunnel type Screw / rail mounting	GMP60-3T - 3CT type	Defined Time characteristics D-Time : 0.2~60sec O-Time : 0.2~15sec	0.5~60A	GMP60-3T 6/60A
	GMP60-TR - 3CT type - Reverse phase protection	Defined Time characteristics D-Time : 0.2~60sec O-Time : 0.2~15sec	0.5~60A	GMP60-3TR 6/60A
Screw type Screw / rail mounting	GMP60-3S - 3CT type	Defined Time characteristics D-Time : 0.2~60sec O-Time : 0.2~15sec	0.5~60A	Please order a penetration type and a terminal block separately and assemble them before use.
	GMP60-3SR - 3CT type - Reverse phase protection	Defined Time characteristics D-Time : 0.2~60sec O-Time : 0.2~15sec	0.5~60A	

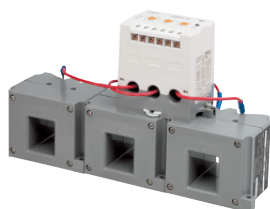

If external CT (current transformer) is used, the product is applicable to a large current of 60A or more.

Technical information

Install	Screw / rail mounting
Tolerance	Current : $\pm 5\%$ Time : $\pm 5\%$ (or $\pm 0.5\text{sec}$)
Frequency	50/60Hz
Aux. contact Ratings	5A/250VAC Resistive load
Insulation resistance	Minimum 100M Ω /500VDC
Lightning impulse voltage	1.2 \times 50 μ s 5kV With standard waveform (IEC60255-22-5)
Fast Transient Burst	2kV/1min (IEC61000-4-4)
Environment	Operation : -25~70°C Storage : -30~80°C Relative humidity : within 80% RH, no condensation
Trip indicator	Red / Green 2 colors LED, Red LED
Application specification	IEC60947-1

GMP60-3TZ/3TZR, 3TN/3TNR, 3SZ/3SZR, 3SN/3SNR



GMP60-3TZ, 3TZR
GMP60-3TN, 3TNR

Specification (Ground fault protection EMPR)

Connection methods	Tunnel type / Screw type
Auxiliary contact	2SPST (1a1b at energization)
Current setting range	0.5-60A
Operating time characteristics	Definite time
Number of built-in CT (deflector)	3
Operating power	AC 100~260V
Return (reset) method/time	Manual/Electrical return
Definite time characteristics	D-Time : 0.2~60sec O-Time : 3sec
Using Inverter Secondary	Available (Exclude GMP60-3TZR, 3TNR) <i>note</i>

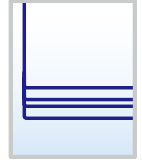

Definite time

Note) If inverter load has an error, turn OFF ground fault function.

Type	GMP60-3TZ, 3TN	GMP60-3TZR, 3TNR
Overcurrent	✓	✓
Lock/Stall	✓	✓
Phase failure	✓	✓
Phase unbalance	✓	✓
Ground Fault	✓	✓
Reverse phase	-	✓
Save the last fault cause	✓	✓

Order type

Mounting type	Model/CT	Operating characteristics	Current setting range	Order type
Tunnel type Screw / rail mounting	Zero phase current detection (0.1~2.5A) (Separate ZCT required)	GMP60-3TZ	0.5 - 60A	GMP60-3TZ 6/60A
		GMP60-3TZR - Reverse phase protection	0.5 - 60A	GMP60-3TZR 6/60A
	Residual current detection (0.5~6A)	GMP60-3TN	0.5 - 60A	GMP60-3TN 6/60A
		GMP60-3TNR - Reverse phase protection	0.5 - 60A	GMP60-3TNR 6/60A
Tunnel type Screw / rail mounting	Zero phase current detection(0.1~2.5A) (Separate ZCT required)	GMP60-3SZ	0.5 - 60A	GMP60-3SZ 6/60A
		GMP60-3SZR - Reverse phase protection	0.5 - 60A	GMP60-3SZR 6/60A
	Residual current detection(0.5~6A)	GMP60-3SN	0.5 - 60A	GMP60-3SN 6/60A
		GMP60-3SNR - Reverse phase protection	0.5 - 60A	GMP60-3SNR 6/60A

Note) 1. In case of terminal connection type, please order a penetration type and a terminal block separately and assemble them before use.
2. In case of ZCT, use ZCT (100mA/40~55mV) for EMPR only.

Technical information

Install	Screw / rail mounting
Tolerance	Current : $\pm 5\%$ Time : $\pm 5\%$ (or $\pm 0.5\text{sec}$)
Frequency	50/60Hz
Aux. contact Ratings	5A/250VAC Resistive load
Insulation resistance	Minimum 100M Ω /500VDC
Lightning impulse voltage	1.2 \times 50 μs 5kV With standard waveform (IEC60255-22-5)
Fast Transient Burst	2kV/1min (IEC61000-4-4)
Environment	Operation : -25~70°C Storage : -30~80°C Relative humidity : within 80% RH, no condensation
Trip indicator	Red / Green 2 colors LED, Red LED
Application specification	IEC 61000, IEC60947-1

Rated specifications / Order type

GMP80



GMP80

Specification

Connection methods	Screw type (No direct connection with Metasol MC)
Auxiliary contact	2SPST (1a1b at energization)
Current setting range	16~80A
Operating time characteristics	Inverse-time
Number of built-in CT (deflector)	2 (R, T type) or 3
Operating power	AC 100~260V
Return (reset) method/time	Manual/Electrical return (Standard) Manual/Auto/Electrical return (GMP80-2SA)
Using Inverter Secondary	Available (Exclude GMP80-3SR)

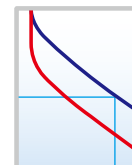

Inverse-time

Model numbering	GMP80-2S	GMP80-2SA	GMP80-3S	GMP80-3SR
Overcurrent	✓	✓	✓	✓
Locked rotor	✓	✓	✓	✓
Phase loss	✓ <i>note)</i>	✓ <i>note)</i>	✓	✓
Phase unbalance	-	-	✓	✓
Reverse phase	-	-	-	✓
Certification	UL, CE	✓	-	✓

Note) The product detects phase failure of the phase (R, T) connected with two CTs in order for protection.

Order type



Mount/Connection	Model numbering system / CT	Setting range	Catalog No.
Screw type Screw / rail mounting	GMP80-2S - 2CT	16 - 80A	GMP80-2S 80A
	GMP80-2SA - 2CT - Automatic return	16 - 80A	GMP80-2SA 80A
	GMP80-3S - 3CT	16 - 80A	GMP80-3S 80A
	GMP80-3SR - 3CT - Reverse phase protection	16 - 80A	GMP80-3SR 80A

Rated specifications

Tolerance	Current : $\pm 5\%$ Time : $\pm 5\%$ (or $\pm 0.5\text{sec}$)
Frequency	50/60Hz
Aux. contact Ratings	5A/250VAC Resistive load
Insulation resistance	Min 100M Ω at 500V DC
Lightning impulse voltage	1.2 \times 50 μs 5kV With standard waveform (IEC60255-22-5)
Fast Transient Burst	2kV/1min (IEC61000-4-4)
Environment	Operation : -25~70°C Storage : -30~80°C Relative humidity : within 80% RH, no condensation
Trip indicator	Red LED (2CT : 1, 3CT : 2)
Application specification	UL508, IEC60947-1

Motor selection / Model numbering system

Motor selection

Current	Current setting range (A)	220~240VAC			380~440VAC		
		3-phase motor rating kW (Hp)		Full Load Current for the Motor(A)	3-phase motor rating kW (Hp)		Full Load Current for the Motor(A)
1.5	0.3-1.5	~0.18	(~0.25)	1.5	0.12~0.55	(~0.75)	1.6
5	1-5	0.18~0.75	(0.25~1)	4.8	0.25~1.5	(0.33~2)	4
22	4.4-22	1.1~4	(1.5~5.5)	18.8	3~7.5	(4~10)	17
20	4-20	0.75~3.7	(1~5)	17.4	2.2~7.5	(3~10)	17
40	8-40	2.2~7.5	(3~10)	34	4~15	(5.5~20)	32.5
80	16-80	4~18.5	(5.5~25)	79	7.5~37	(10~50)	74
06	0.5-6	0.09~0.75	(0.13~1)	4.8	0.12~2.2	(0.13~3)	5.5
30	3-30	0.37~5.5	(0.5~7.5)	26	1.1~11	(1.5~15)	24
60	0.5-60	1.1~11	(1~15)	48	3~22	(4~30)	46.5

Note) The above data can be different depending on a motor degree and a manufacturer. They are the reference values of AC Degree 3 Standard Squirrel Cage Motor.

Model numbering system

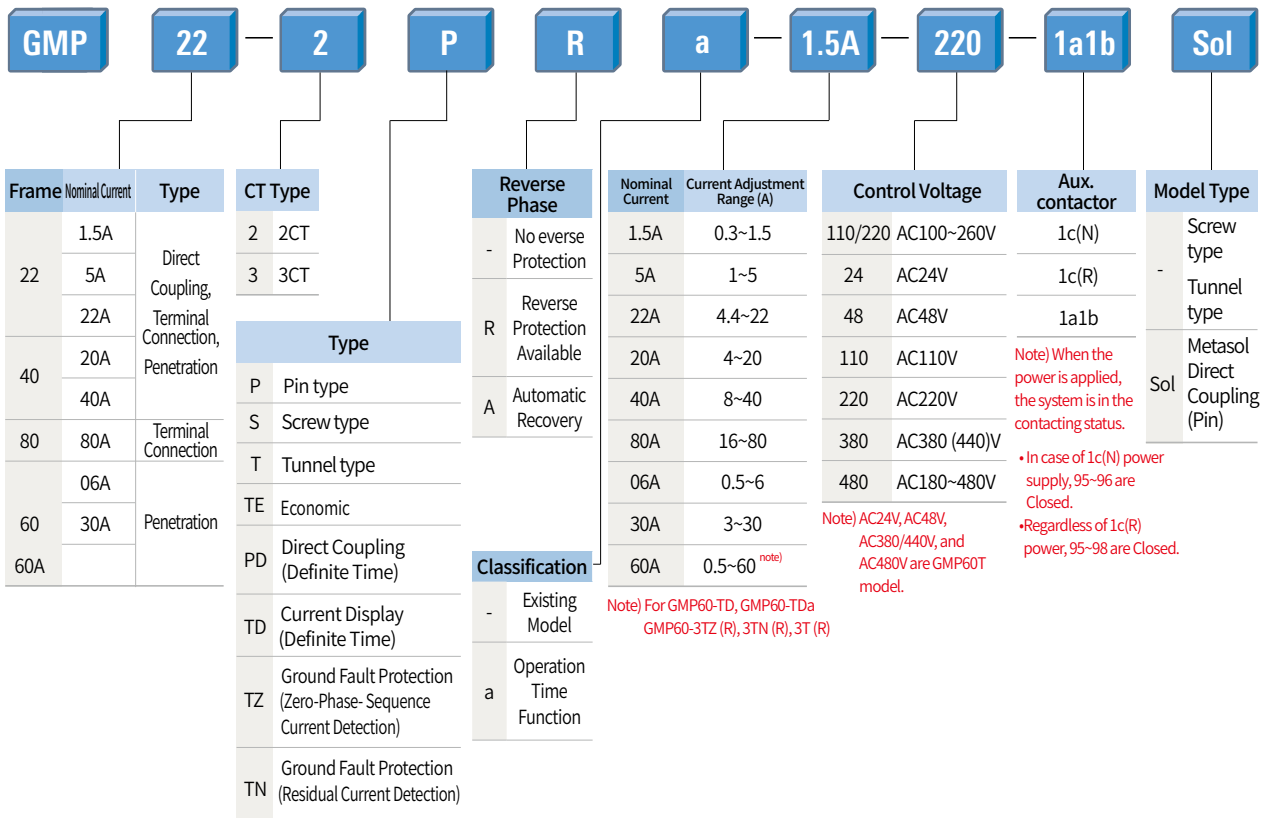

Operation & setting method

Inverse time characteristic

1. Check the rated voltage and apply the control power to A1 and A2 terminal

If 220V power is supplied to a model for AC110V, overvoltage occurs and thereby EMPR has a failure.

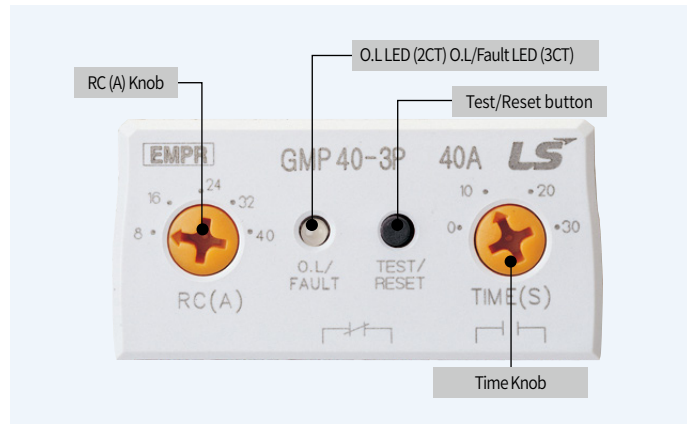

2. With Test/Reset button, check that output contact works normally.

- 1) If Test/Reset button is clicked once, O.L (display lamp) representing Trip is turned on. If EMPR is Tripped, output contact works.
- 2) If Test/Reset button is clicked again at the time of EMPR Trip, the display lamp is turned off and the equipment resets to its original state.
- 3) Auto reset function (Auto Reset)
 - In case of overcurrent Trip, the equipment automatically returns after one minute (GMP22-2PA/GMP40-2PA),
 - In case of overcurrent Trip, the equipment automatically returns after 0~120 seconds (variable setting) (GMP60T-A).

Note) To prevent a Trip accident, Test/Reset button is designed not to work while a motor is running.

3. Set the operating time

An operating time is based on 600% of rated current in the characteristic curve.

- 1) Set up the position of operating time control knob (Time Knob) in consideration of a starting time and starting current.
(E.g., on the assumption that a starting current accounts for 600% of normal operating current and a starting time is 10 seconds, set Time Knob to about 11~12 seconds with 10-20% margin.)
- 2) An available operating time ranges from 0 to 30 seconds.
- 3) In case that Time Knob is set to 10 seconds, if the starting current or 600% of rated current is supplied for 10 seconds, immediate Trip occurs.

Note) For a motor with frequent forward/reverse starting, such as a motor of crane or hoist, an EMPR with the characteristic of definite time is recommended

4. Set up a rated current.

Setting is based on the rated current of a motor (normal operating current).

- 1) Check that a motor's rated current is within the current control range of EMPR.
- 2) Set RC (Rating Current) Knob up to the maximum and run the motor.
- 3) In normal operation state, slowly turn RC Knob counter clockwise and stop at the point that overcurrent display lamp (O.L) flickers. At this point, the actual load current value (100%) of the motor is displayed.
- 4) From the point, turn RC Knob clockwise. Set up the knob at this point that O.L lamp is turned off (less than motor full load current).
(e.g., when overcurrent display lamp is turned off at 20A, set current = $20 \times 1.1 = 22A$)

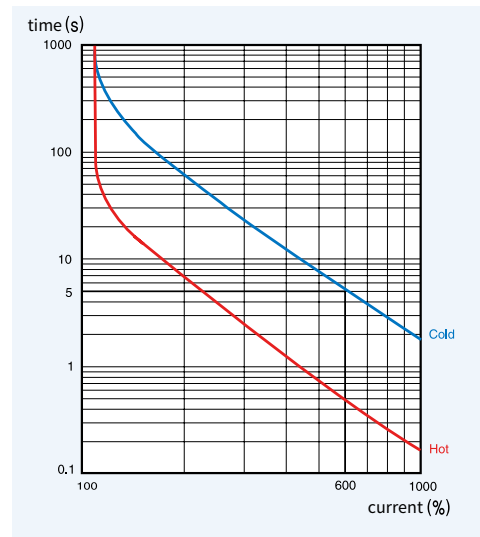

5. Check status of operation by LED

2CT : Overcurrent, Phase failure, Lock/Stall

3CT : Overcurrent, Phase failure, Reverse phase, Phase unbalance, Lock/Stall

1) In case of overcurrent

- If there will be an overcurrent during motor operation, the red color of LED will flicker at 0.4 second intervals.
After tripping because of overcurrent, the red color of LED will light up.

2) In case of phase failure (2CT EMPR can protect motor from R or T phase failure.)

- If a motor stops running due to phase failure, stall current flows. As a result, it is possible to protect the motor against overcurrent.
If the motor keeps running in phase failure, it is necessary to protect against phase failure.
- If phase failure occurs in three-phase load (3CT), Trip occurs within three seconds. (O.L LED is turned on)
R-phase phase failure - Fault LED flickers once (0.4 second) at an interval of three seconds.
S-phase phase failure - Fault LED flickers twice at an interval of three seconds.
T-phase phase failure - Fault LED flickers three times at an interval of three seconds

3) In case of phase unbalance

- If phase unbalance factor of three phase is about 50% or more after its calculation, Fault LED only flickers at an interval of 0.4 second and then trips after five seconds. (After Trip, the same display as phase failure appears.)

4) In case of Reverse phase

- Trip occurs within 1 second, and the lamp flickers red and green in turn (GMP22/40/60-□R type) or O.L LED and Fault LED flicker (GMP80-3SR).
In this case, to detect reverse phase, a load current should be more than the minimum current setting range of EMPR.

5) LED operation status

	Condition	LED Status	LED Diagram	Remark	
Operating status	Normal	LED OFF			
	Over current	0.4 Second intervals			
	Phase unbalance (50%, 3CT)	0.4 Second intervals		GMP 80-3S/3SR model, only red color LED will flicker.	
Tripped status	Over current	O.L LED light up			
	Phase failure (3CT)	R	1 time for 3 seconds		GMP 80-3S/3SR model, O.L LED will light up and also FAULT LED will flicker.
		S	2 time for 3 seconds		
		T	3 time for 3 seconds		
Phase failure (2CT)	Red LED light up for 0.9 sec LED goes off for 0.1 sec				
Reverse phase (3CT)	Red & Green color LED flicker alternately		GMP 80-3S/3SR model, Red/Green LED will flicker.		

Note) There are two red color LEDs for O.L (Overload) & Fault in the model of GMP80-3S/SR

Operation & setting method

Definite time characteristic 1

1. Check the rated voltage and apply the control power to A1 and A2 terminal

If 220V power is supplied to a model for AC110V, overvoltage occurs and thereby EMPR has a failure.

2. Check the Test/Reset button operation

- 1) If Test/Reset button is clicked once, O.L (display lamp) is turned on, EMPR is Tripped, and output contact runs.
- 2) If Test/Reset Button is clicked once again when EMPR is Tripped, the display lamp is turned off and the equipment returns to its original state (Reset).

Note) 1. To prevent a Trip accident, Test/Reset button is designed not to work while a motor is running. 2. If Test/Reset button is clicked twice within 0.5 second, it is possible to check the final failure cause.

3. Set the operating time

D-Time (Delay Time) : 0~30 sec

It refers to the time of delaying EMPR operation in order to prevent Trip from a motor's starting current.

- 1) With the use of D-Time Knob, set up a delay time taken from motor starting to normal running current.
- 2) If you are unaware of a start delay time, set it to the maximum time and measure how long it takes to reach the normal starting current of the motor, and then set it up again. (Reference: in case of general load, set it to about 3~5 seconds.)

Note) If actual load current fails to detect during a set time, a motor can be damaged. Set up a delay time rightly.

O-Time (Operating Time) : 0~15 sec

It refers to the time taken from the start of overcurrent to EMPR Trip. After the set O-Time, EMPR is Tripped.

- 1) With the use of O-Time Knob, set up an operating time.
- 2) If O-Time is the minimum value, EMPR is immediately tripped as soon as overload occurs. (Reference: generally, set it to 4~6 seconds.)

A-Time (Auto Reset Time): 0~120 seconds; set up an automatic reset time in auto reset type.



4. Set the operating current

Setting is based on the rated current of a motor (normal operating current).

- 1) Check that a motor's rated current is within the current control range of EMPR.
- 2) Set RC (Rating Current) Knob up to the maximum and run the motor.
- 3) In normal operation state, slowly turn RC Knob counter clockwise and stop at the point that overcurrent display lamp (O.L) flickers. At this point, the actual load current value (100%) of the motor is displayed.
- 4) From the point, turn RC Knob clockwise. Set up the knob at this point that O.L lamp is turned off (less than motor full load current). Generally, set it to 110~120% of actual load current (set to a value lower than a motor full load current).

5. Check the LED condition when operation

1) GMP60T

Condition		Red O.L LED	Remarks
Operation normal	Off		
Overcurrent	Flicker		Flicker during overcurrent
Trip over-current	On		The EMPR is tripped

2) GMP60-3T/3TR

The same as the LED operation state in operation.

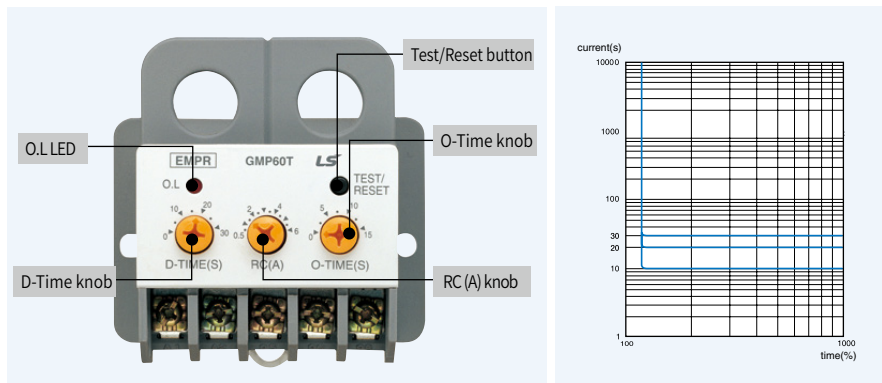

Definite time characteristic 2 (GMP60-TD, TDa)

1. Function & setting menu

- 1) Set up “Slide S/W, Rated current, and Current transformer ratio” on the basis of a motor’s full load current.
To change Slide S/W, turn OFF control power. In the No. 1 menu (1.Ct), make sure to change to a relevant rated current.

Full Load Current	Wire penetration	Slide S/W	Rated current (1.Ct)	Current ratio (5.Ctr)
0.6A or less	4 times	6A	6A	0.25
0.7~1.5A	Twice	6A	6A	0.5
1.6~6A	Once	6A	6A	1
6~60A	Once	60A	60A	10
60~100A	Once	6A	6A	20
100A or more	Once	6A	6A	CT Ratio (Primary/Secondary)



- 2) In the '0000' display state, click Test/Reset button to go to Setting Mode ('Test' is displayed on screen).
Click FUN button to search for items and set up various values with the use of SEL button.
- 3) Push FUN button until 'Stor' is displayed, and make sure to save a value with SEL button.
- 4) If saved completely, '0000' is displayed on screen. If no button operation occurs in ten seconds in the value setting process, the current screen goes to initial screen.
- 5) If Test/Reset button is clicked in operation, it is possible to check “Set Current/D-T/O-T”.
In case of Trip, it is possible to check failure current/failure cause with the use of SEL button.

Note) While a motor is running, a set value is unable to be changed, but is able to be checked only.

2. Setting menu

FUNC	SEL	Description	Default Value	Remarks
1.Ct-4	6A/60A	Current type selection	6A	Set the same with rated current S/W
20-t	0.5/1~30 (SEC)	Trip time setting	30	Set 0.5 to 30 sec
3d-t	1~60/1 (SEC)	Time delay setting	60	Set 1~60 sec
4r-c	0.5~6.0/5~60	Rated current setting	6/60	-
5Ctr	0.25/0.5/1~120	Current ratio setting	1	-
6P-F	OFF/on	Phase loss enable	Off	Operation in less than 3 sec
7W-C	OFF/30~70 (%)	Undercurrent setting	Off	For TDa model only (Overcurrent operation)
8R-r	OFF/1~20 (MIN)	Automatic reset setting	Off	For TDa model only (Off, 1~20min)
95r-t	OFF/10~8760	Operation hour setting	Off	For TDa model only
Rt-r-t	-	Total running hour check	-	For TDa model only (Up to 10 years, 1 hour unit)
br-t	-	Running hour check	-	For TDa model only (Up to 10 years, 1 hour unit)
Sto	-	Store	-	-

Note) 1. Check final failure cause: push FUN+SEL (combination buttons) (if there is no failure cause, 'non' is displayed.)

2. Operating time setting: 'OrH' is displayed after a set operating time(OF, f10-8760 hours setting allowed)

3. Fault status configuration

Protection	FND	Description	Remarks
Over current	O-L	More than set current : Within the set time	
Undercurrent	U-C	Lower than the undercurrent set ratio : Within 3S	For TDa model only
Phase Loss	PF-r	Over 70% of the rate of unbalance : Within 3S	R Phase Loss
	PF-t	Over 70% of the rate of unbalance : Within 3S	T Phase Loss
LOCK	Loc	More than lock set current ratio : Within 1S	
Approaching Running Time	OrH	When Running time approaches at setting time	For TDa model only

Note) 1. If the set operating time in '95r-t' passes, 'OrH' is displayed and EMPR has no output.)

2. How to check 'OrH' and 'r-t'

FUNC	Description					
t-r-t	Press the SEL button	Daily Display	Press the SEL button	Time Remaining, Display minutes		
r-t	Press the SEL button	Operation time indicator	Press the SEL button	Daily Display	Press the SEL button	Time Remaining, Display minutes

In case of 't-r-t'; if power is Off, the minute unit based time is removed.

If 'r-t' is checked, an operating time represents a total running time taken until a motor is turned Off. It is displayed in the units of day, hour, and minute.

Operation & setting method

Definite time characteristic 3 (GMP60-3TZ, TZR / 3TN, TNR)

1. This product has the characteristic of definite time.

For setting, see pages 21 & 22.

2. Protective function: overcurrent, locked rotor, phase loss, phase unbalance, ground fault (and phase reverse)

- 1) Overcurrent : trip within 3 sec. after D-time at 105% or more
- 2) Locked rotor : trip within 1 sec. after D-time at 300% or more
- 3) Phase loss : trip within 3 sec. (phases unbalance rate over 70%)
- 4) Phase unbalance : trip within 5 sec. (phases unbalance rate over 50%)
- 5) Ground fault : trip within 0.5 sec. after D-time at over 110% or under 90% of set value
- 6) Reverse phase : if two out of R, S, and T phases are changed with each other and a current flows.
Run in 1 second (no detection after TDim- e)

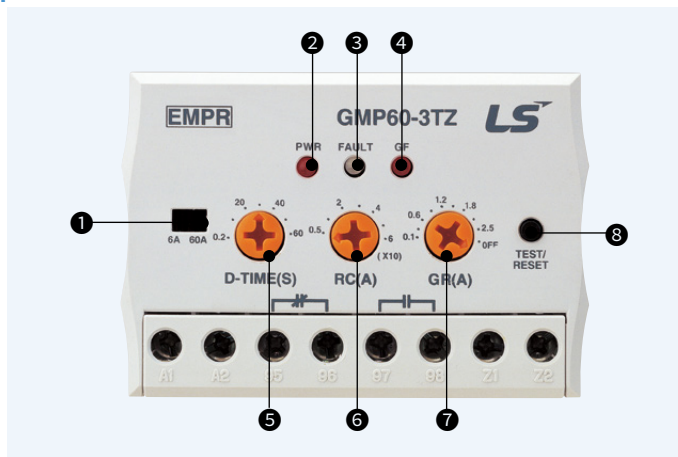

- Note) 1. Make power off before changing the rated current with S/W ①
 2. The setting range of RC (A) KNOB ⑥ is recognized as 0.5 ~ 6A or 5 ~ 60 According to the setting value of S/W ①. The value of the scale for RC (A) KNOB ⑥ is 0.5, 1, 2, 3, 4, 5, 6 or 5, 10, 20, 30, 40, 50, 60(A) from the left.
 3. Last fault cause function indicates the LED status for the last TRIP.

3. Overcurrent trip time

- 1) Time delay(D-time) setting: between 0.2-60 sec.
- 2) Trip time(O-time) setting: fixed at 3 sec.

4. Other functions

- 1) Last fault cause data stored
 - to display it press Test/Reset button 2 times within 0.5 sec.
 - PWR LED flicking in case of no fault

Note) In case of load less than minimum rating of EMPR make the number of penetrating through CT more than 2 times. If not, error may happen to phase loss.

5. Status of LED configuration

NO	Function	Setting	Description	Remark
①	6A/60A	Slide switch	Maximum rated current (6A/60A) setting	-
②	PWR.	Red LED	Lights up when power is ON Blinking in the failure mode	-
③	Fault	Red / Green LED	Overcurrent / unbalance in progress : Overcurrent TRIP : Phase loss (unbalance) TRIP · R-phase : · S-phase : · T-phase : · Reverse phase :	Red LED Green LED
④	GF	Red LED	Lights up after blinking in the event of ground fault	-
⑤	D-Time (S)	KNOB	Delay time (0.2 to 60 sec.)	-
⑥	RC (A)	KNOB	Rated current setting: 0.5~6A/5~60A	-
⑦	GR (A)	KNOB	Zero phase current detection type Sensitivity current setting (0.1~2.5A) Residual current detection type Sensitivity current setting (0.5~6A)	-
⑧	Test/Reset	Button	TRIP / RESET alternately perform 1. Check relay contacts - displays fault cause 2. RESET	Pressing 2 times within 0.5 sec. the final failure cause is displayed

Terminal configuration

GMP22-2P (1c) Sol
GMP22-2PD (1c) Sol

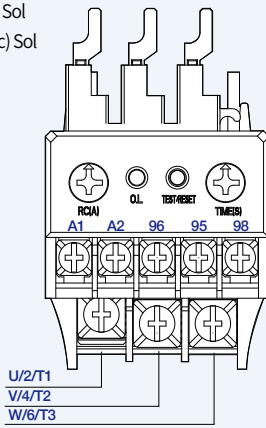

GMP22-2P (1a1b) Sol
GMP22-3P Sol
GMP22-2PA (1a1b) Sol
GMP22-3PR Sol

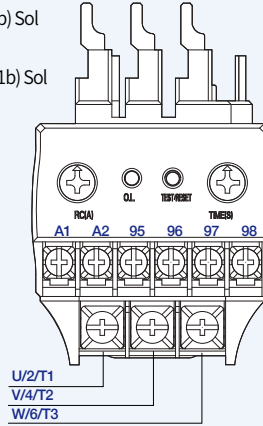

GMP40-2P Sol
GMP40-2PD Sol
GMP40-2PA Sol
GMP40-3P Sol
GMP40-3PR Sol

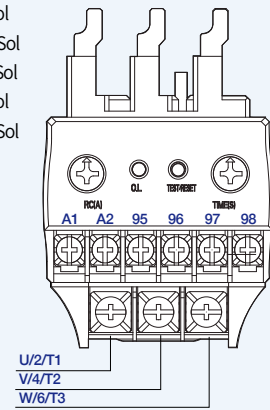

GMP22-2S
GMP22-3S
GMP22-3SR
GMP40-2S
GMP40-3S
GMP40-3SR

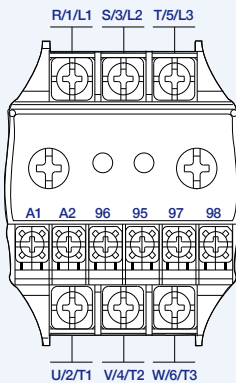

GMP22-2T
GMP22-3T
GMP22-3TR
GMP40-2T
GMP40-3T
GMP40-3TR

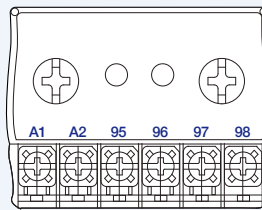

GMP80-2S
GMP80-3S
GMP80-3SR

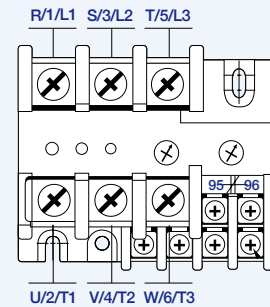

GMP60T
GMP60TE
GMP60TA

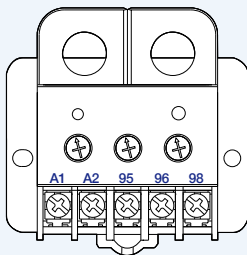

GMP60-TD
GMP60-TDa

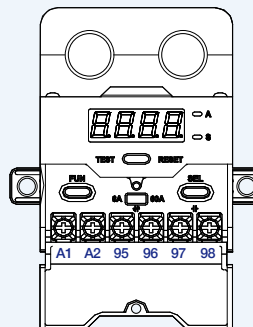

GMP60-3TZ, TZR
GMP60-3TN, TNR
GMP60-3T, TR

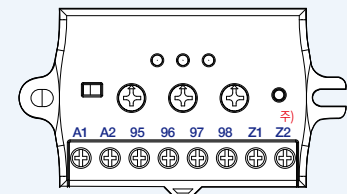

Engrave	Description
A1, A2	Input terminal for operation power
95, 96, 98	Output terminals at power-on
95-96	When the power is ON (NC contact output)
97-98	When the power is ON (NC contact output)
Z1, Z2	ZCT output connection
U/2/T1, V/4/T2, W/6/T3	Power side connection
R/1/L1, S/3/L2, T/5/L3	Load side connection

- Note) 1. GMP60-3TN/3TNR and GMP60-3T/3TR models are not wired to Z1 and Z2 terminals.
2. In case of 1c(N), only if control power (A1, A2) is On, output contact occurs (if power Off or Trip, 95-96: Open, 95-98: Close)
3. In case of 1c(R), output contact occurs regardless of control power (A1, A2). (Contact chattering can occur in a very vibrating place.)

Terminal configuration / Wiring & cable connection

GMP22-2P 1c(N)
 GMP22-2P 1c(R)
 GMP60T 1c(N)
 GMP60T 1c(R)

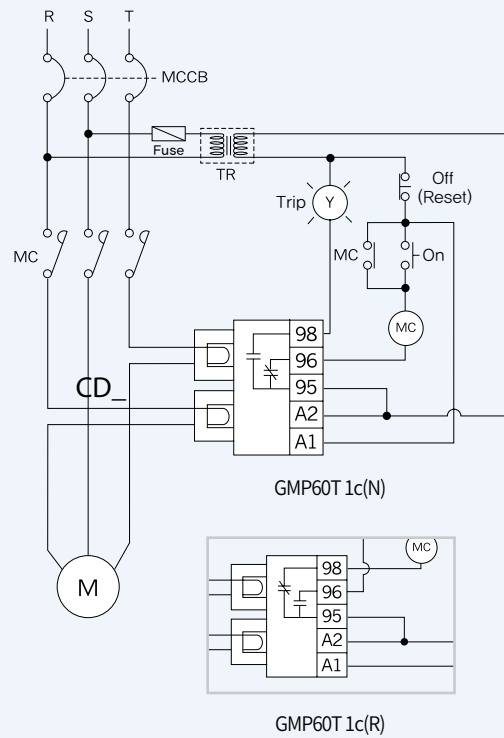
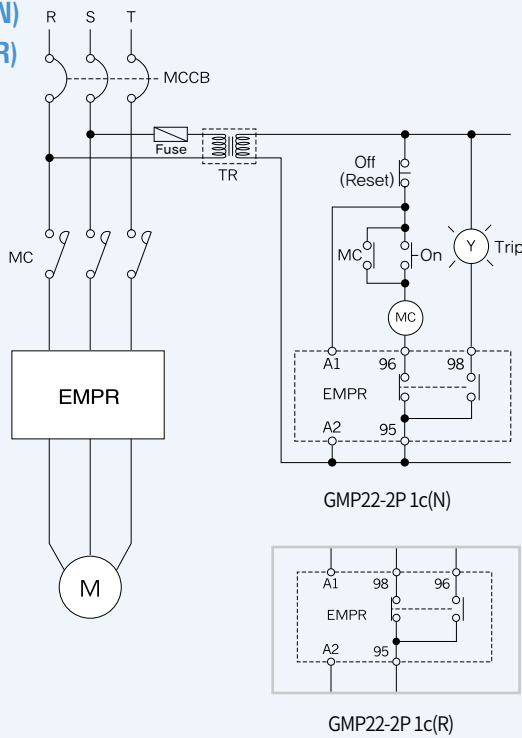

Note) 1. In case of 1c(N), only if control power (A1, A2) is On, output contact occurs (if power Off or Trip, 95-96 : Open, 95-98 : Close)
 2. In case of 1c(R), output contact occurs regardless of control power (A1, A2). (Contact chattering can occur in a very vibrating place.)

GMP-(1a1b)

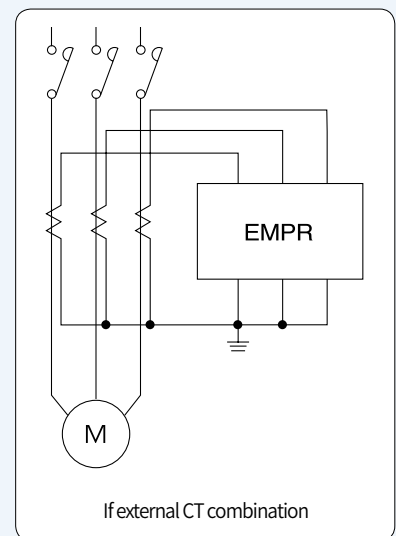
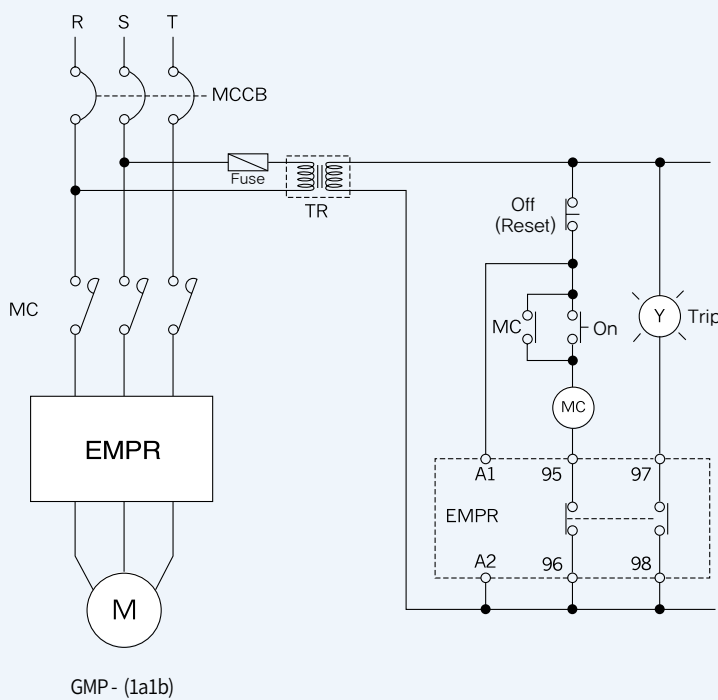

Note) 1. To use a single-phase motor, connect it with R & T phases of EMPR. 3CT Type is not allowed in a single-phase motor.
 2. Output contact occurs only if control power (A1, A2) is On. (1a1b)

GMP60-3TZ, TZR
GMP60-3TN, TNR
GMP60-3T, 3TR

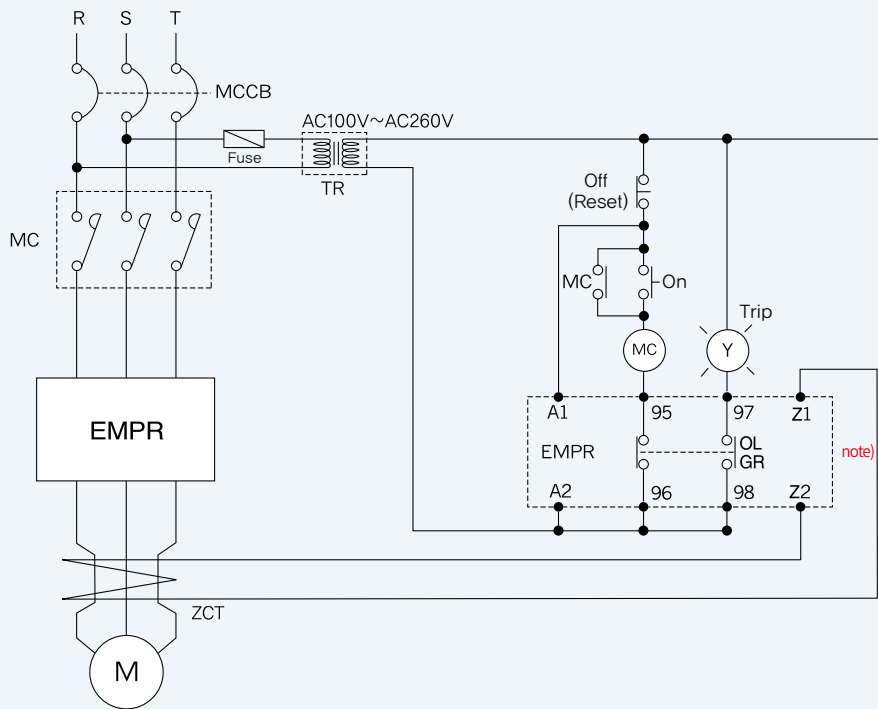

- Note) 1. In case of GMP60-3TZ/3TZR model, wire ZCT to Z1 and Z2 terminals.
 2. In case of GMP60-3TN/3TNR and GMP60-3T/3TR models, do not wire ZCT to Z1 and Z2 terminals. (no need of ZCT)
 3. Output contact occurs only if control power (A1, A2) is On. (1a1b)

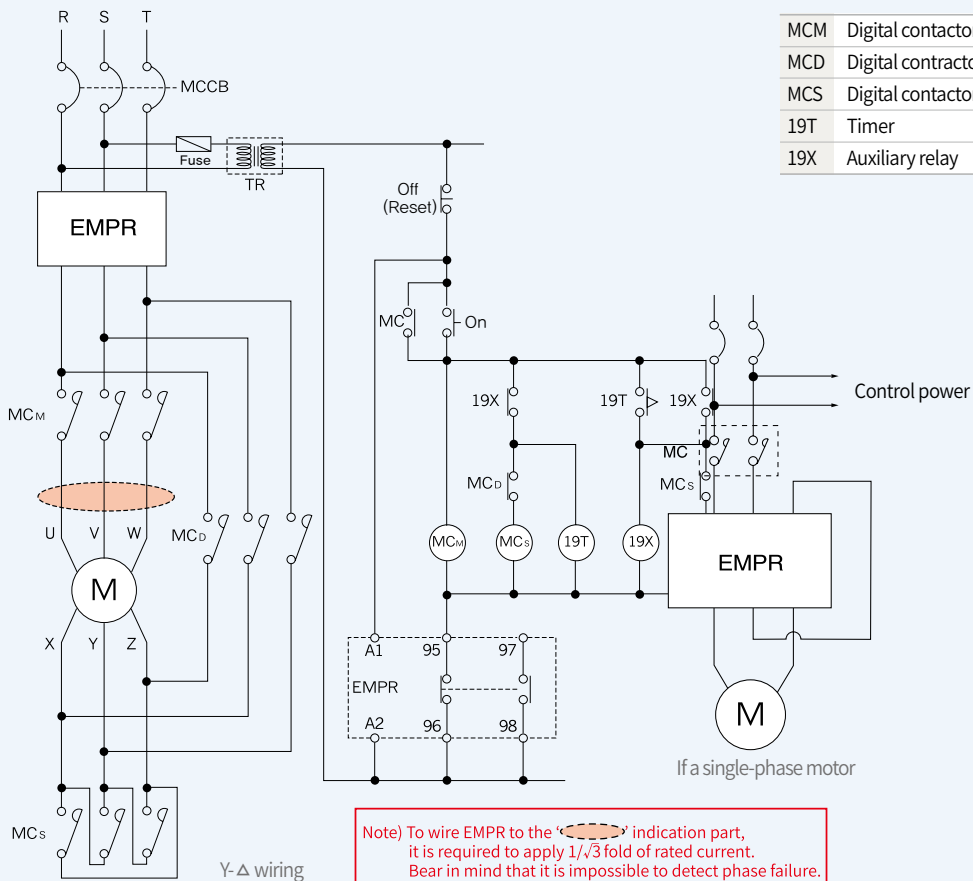

- Note) 1. A reverse phase protection model (-R Type) is not applicable to a single-phase motor.
 2. GMP60-3TN is unable to provide ground fault protection for a single-phase motor. (GMP60-3TZ applied)
 3. Output contact occurs only if control power (A1, A2) is On. (1a1b)

Dimensions

- GMP22-2P (1c) Sol
- GMP22-2PD (1c) Sol

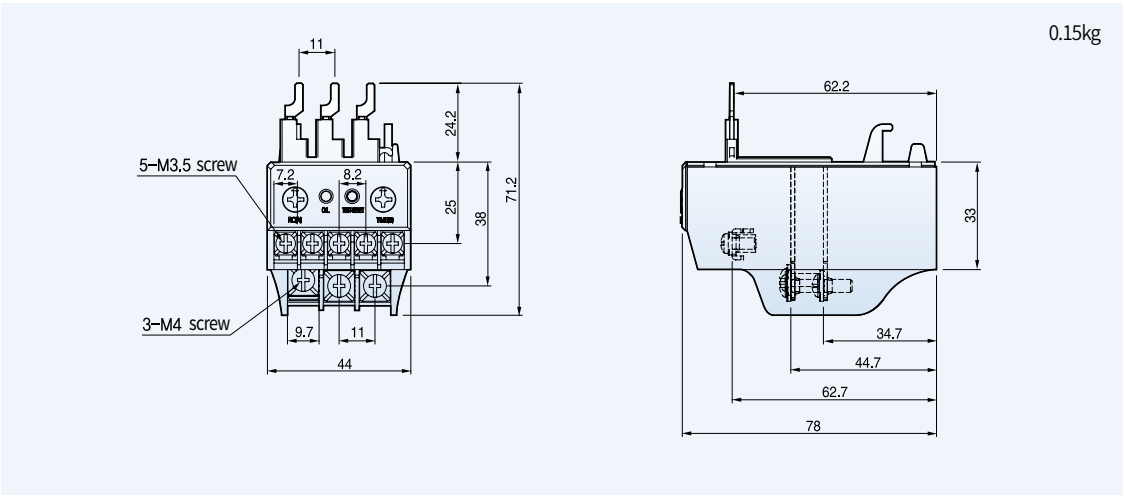

- GMP22-2P (1a1b) Sol
- GMP22-3P Sol
- GMP22-2PA (1a1b) Sol
- GMP22-3PR Sol

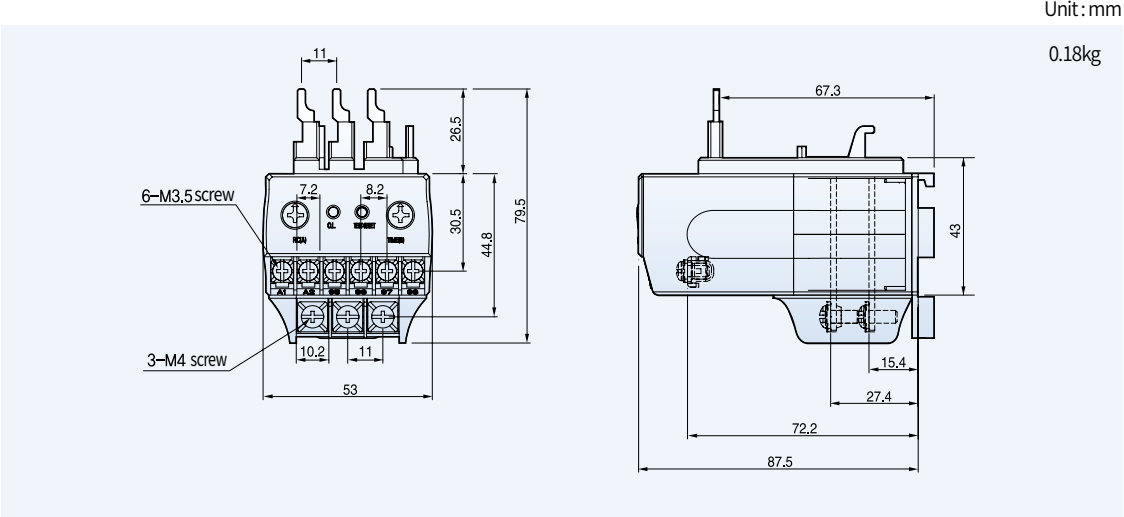

- GMP40-2P Sol
- GMP40-2PD Sol
- GMP40-2PA Sol
- GMP40-3P Sol
- GMP40-3PR Sol

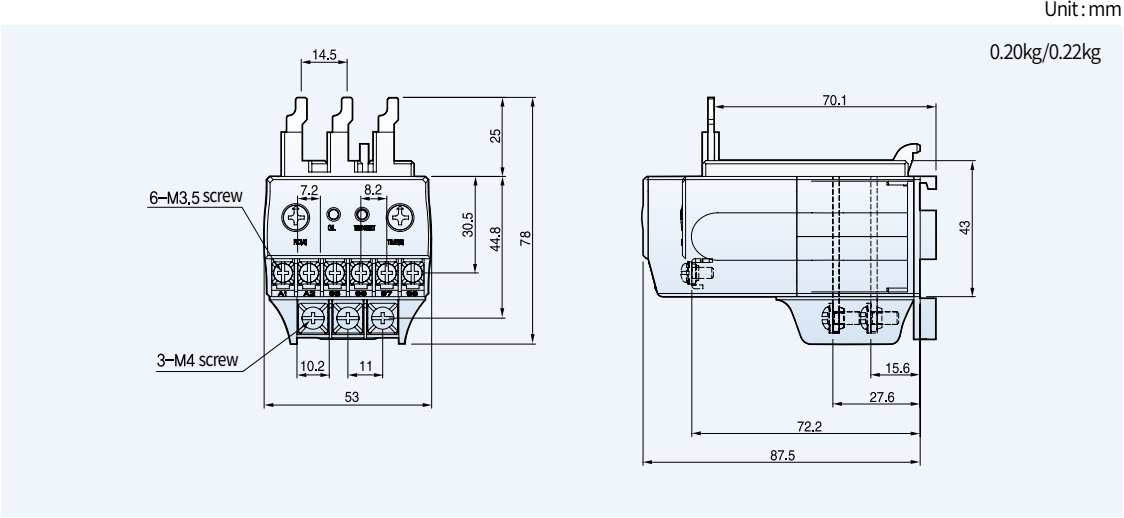

Unit: mm

0.19kg/0.21kg

- GMP22-2S
- GMP22-3S
- GMP22-3SR
- GMP40-2S
- GMP40-3S
- GMP40-3SR

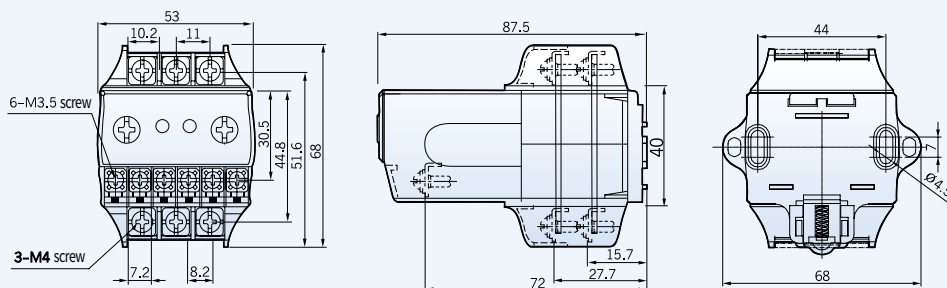

Unit: mm

0.14kg/0.16kg

- GMP22-2T
- GMP22-3T
- GMP22-3TR
- GMP40-2T
- GMP40-3T
- GMP40-3TR

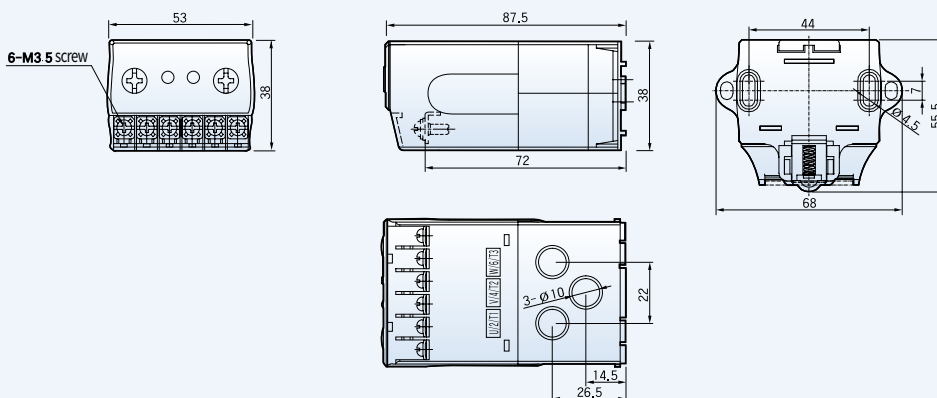

Unit: mm

0.42kg/0.46kg

- GMP80-2S
- GMP80-3S
- GMP80-3SR

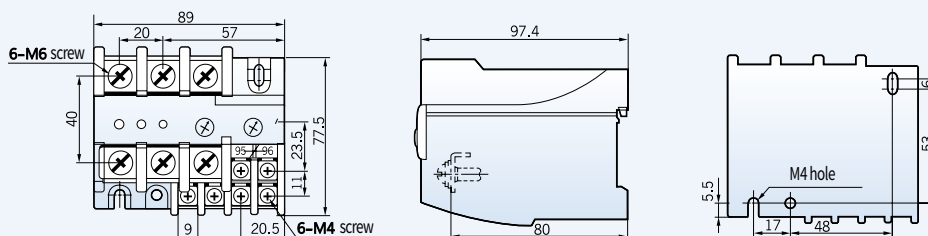

Dimensions

- GMP60T
- GMP60TE
- GMP60TA

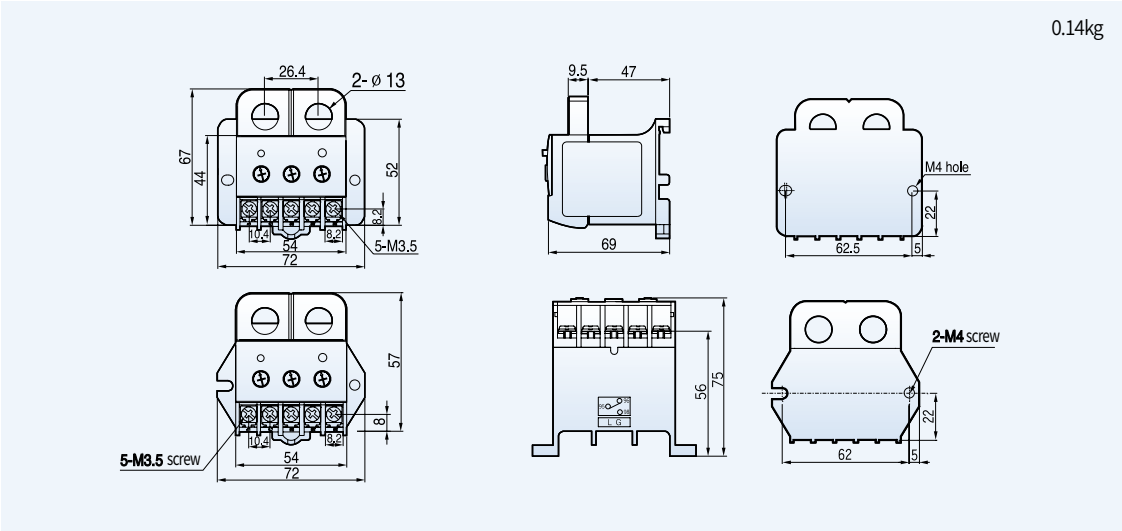

- GMP60-TD
- GMP60-TDa

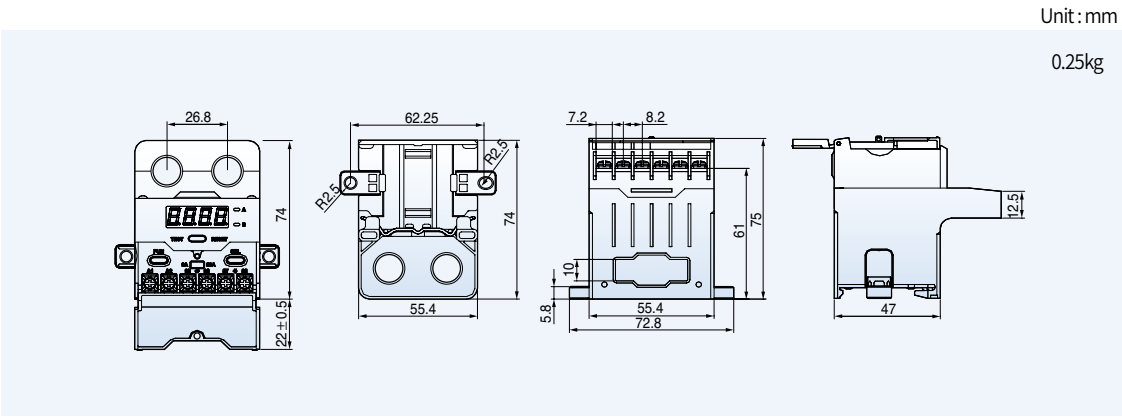

- GMP60-3TZ, TZR
- GMP60-3TN, TNR
- GMP60-3T, TR

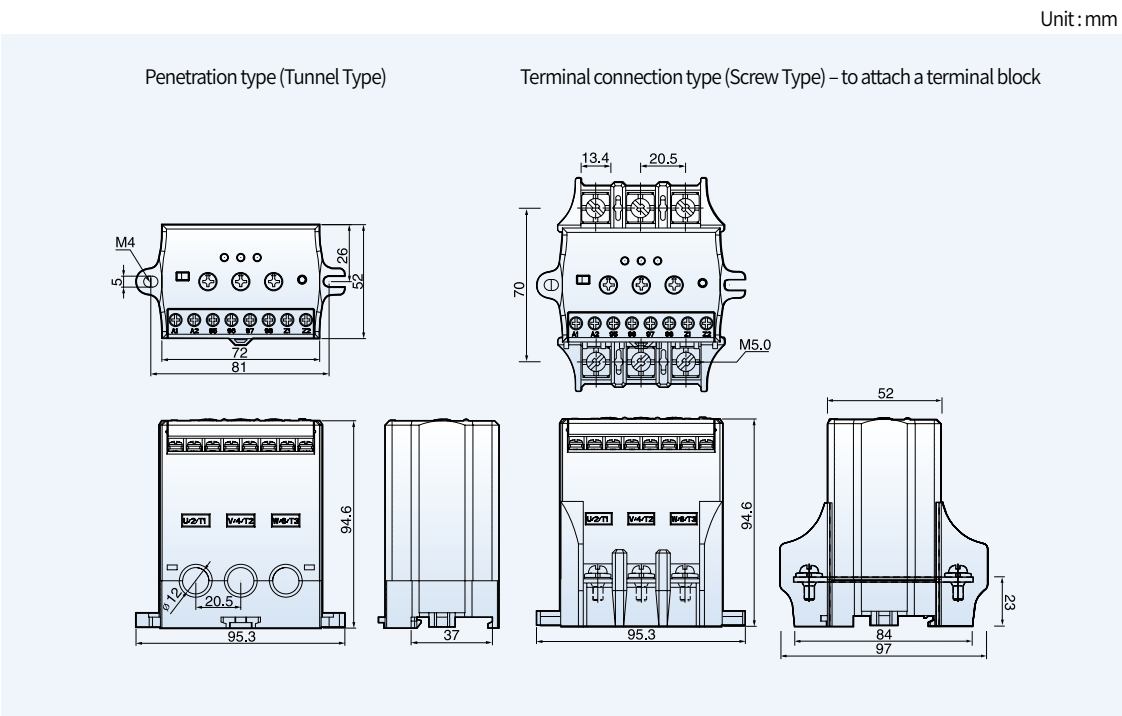

Note) If terminal connection type (Screw Type) is used, purchase a terminal block separately.

Large empty rectangular area for writing or drawing.



Safety Instructions

- For your safety, please read user's manual thoroughly before operating.
- Contact the nearest authorized service facility for examination, repair, or adjustment.
- Please contact qualified service technician when you need maintenance. Do not disassemble or repair by yourself!
- Any maintenance and inspection shall be performed by the personnel having expertise concerned.



- According to The WEEE Directive, please do not discard the device with your household waste.



www.lselectric.co.kr

■ **Headquaters**

127, LS-ro(hogye-dong) Dongan-gu, Anyang-si, Gyeonggi-Do, 14119, Korea

■ **Seoul Office**

LS Yongsan Tower, 92, Hangang-daero, Yongsan-gu, Seoul, 04386, Korea
Tel: 82-2-2034-4916, 4684, 4429

■ **Overseas Subsidiaries**

- **LS ELECTRIC Japan Co., Ltd. (Tokyo, Japan)**
Tel: 81-3-6268-8241 E-Mail: jschuna@lselectric.biz
- **LS ELECTRIC (Dalian) Co., Ltd. (Dalian, China)**
Tel: 86-411-8730-5872 E-Mail: jiheo@lselectric.com.cn
- **LS ELECTRIC (Wuxi) Co., Ltd. (Wuxi, China)**
Tel: 86-510-6851-6666 E-Mail: jdyim@lselectric.com.cn
- **LS ELECTRIC Vietnam Co., Ltd.**
Tel: 84-93-631-4099 E-Mail: jhchoi4@lselectric.biz (Hanoi)
Tel: 84-28-3823-7890 E-Mail: sjbaik@lselectric.biz (Hochiminh)
- **LS ELECTRIC Middle East FZE (Dubai, U.A.E.)**
Tel: 971-4-886-5360 E-Mail: hschoib@lselectric.biz
- **LS ELECTRIC Europe B.V. (Hoofddorf, Netherlands)**
Tel: 31-20-654-1424 E-Mail: europartner@lselectric.biz
- **LS ELECTRIC America Inc. (Chicago, USA)**
Tel: 1-800-891-2941 E-Mail: sales.us@lselectricamerica.com

■ **Overseas Branches**

- **LS ELECTRIC Tokyo Office (Japan)**
Tel: 81-3-6268-8241 E-Mail: jschuna@lselectric.biz
- **LS ELECTRIC Beijing Office (China)**
Tel: 86-10-5095-1631 E-Mail: chendm@lselectric.com.cn
- **LS ELECTRIC Shanghai Office (China)**
Tel: 86-21-5237-9977 E-Mail: khpaek@lselectric.com.cn
- **LS ELECTRIC Guangzhou Office (China)**
Tel: 86-20-3818-2883 E-Mail: chenxs@lselectric.com.cn
- **LS ELECTRIC Chengdu Office (China)**
Tel: 86-28-8670-3201 E-Mail: yangcf@lselectric.com.cn
- **LS ELECTRIC Qingdao Office (China)**
Tel: 86-532-8501-2065 E-Mail: wangzy@lselectric.com.cn
- **LS ELECTRIC Nanjing Office (China)**
Tel: 86-25-8467-0005 E-Mail: ylong@lselectric.com.cn
- **LS ELECTRIC Bangkok Office (Thailand)**
Tel: 66-90-950-9683 E-Mail: sjleet@lselectric.biz
- **LS ELECTRIC Jakarta Office (Indonesia)**
Tel: 62-21-2933-7614 E-Mail: dioh@lselectric.biz
- **LS ELECTRIC Moscow Office (Russia)**
Tel: 7-499-682-6130 E-Mail: jdpark1@lselectric.biz
- **LS ELECTRIC America Western Office (Irvine, USA)**
Tel: 1-949-333-3140 E-Mail: ywyun@lselectricamerica.com



Technical Question or After-sales Service

Customer Center-Quick Responsive Service, Excellent technical support | **82-1644-5481**